

# 20K Swing Check Valve

20SOB  
B.C.  
RF-flanged

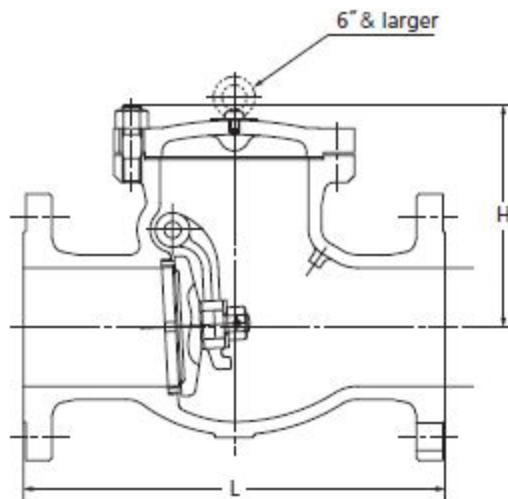

F-F dimension : JIS B 2002  
End flanges : JIS B 2239 20K

120°C Static water..... 2.75MPa  
220°C Steam, air, gas, oil..... 2.45MPa  
300°C Steam, air, gas, oil..... 2.26MPa  
350°C Steam, air, gas, oil..... 1.96MPa

## Materials

Parts	JIS material
Body	FCD-5
Cover	FCD-5
Disc	SUS 403 (8"~12": SCPH2+13Cr)
Disc nut	SS 400 (5"~12": SUS304)
Body seat ring	SUS 403 (2"~4": SCS1)
Arm	SCS13A (5"~12": SFVC2A or SCPH2)
Hinge pin	SUS 403
Split pin	SUS 304
Plug	SS 400
Washer	SS 400
Gasket	Asbestos-free
Cover bolt / nut	S45C

## Dimensions

Size	mm									
	mm inch	50	65	80	100	125	150	200	250	300
L		267	292	318	356	400	444	533	622	711
H		135	145	160	185	220	240	275	335	370

NOTE : For flange dimensions refer to Page 40.