



# B I-LOK<sup>®</sup>

## TUBE FITTINGS

*IHARA SCIENCE CORPORATION*

## ■ BI-Lok Tube Fittings have been made by Ihara Science Corporation

Ihara Science Corporation manufactures and markets **BI-Lok** tube fittings, which are double ferrule type high quality compression fittings, and other systems components through a global sales network as the best fit piping components for every application of every fluids in various fields. The high quality serviceability of **BI-Lok** tube fittings has been proven in 20 years of supply to customers over the world, which has been performed by **Ihara Science Corporation**.

## ■ ADVANTAGES OF BI-Lok

© The industrial leader in fluid power and instrumentation systems, Ihara Science Corporation has established and continues to upgrade the advantage of BI-Lok tube fittings as shown below.

1. Easy assembling without welding or threading
2. High quality tightness realized from high quality materials and precision manufacturing

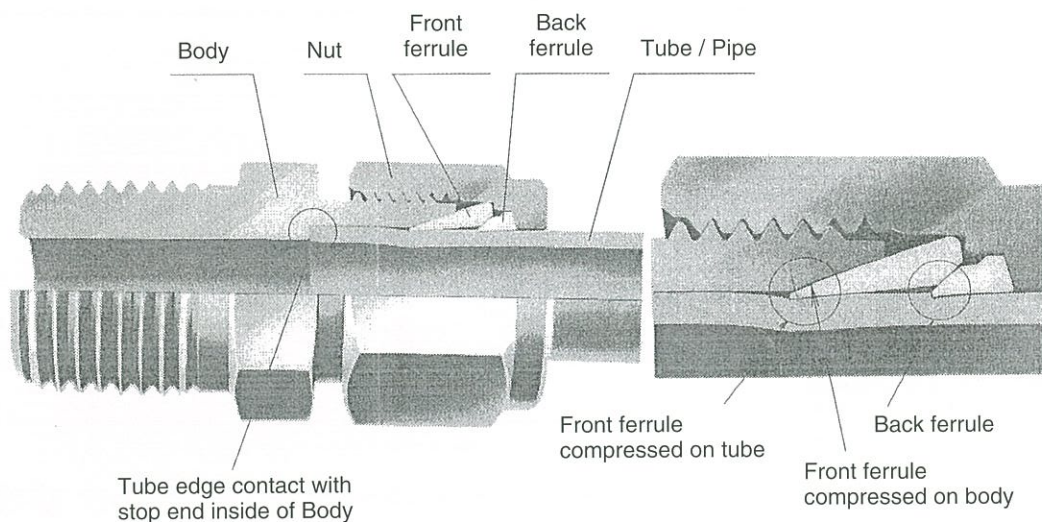

- ① **Front ferrule** secures a perfect seal as compressed tightly on tube by back ferrule.
- ② **Back ferrule** bites tube tightly to prevent a disconnection upon receiving the reaction force from front ferrule.
- ③ **Body, Nut & Ferrules** are manufactured according to their requirements to achieve the best serviceability.
- ④ **Tube / Pipe** is inserted through nut so as to contact with internal stop end of body firmly.

## Part Number / Ordering Number

Please indicate the following part number of BI-Lok tube fittings when you order or request for information.

      
①
D  
②
CT  
③
4 – R4  
④      ⑤
SS  
⑥

① Fitting series : Inch series : None

Metric and Schedule series fittings : M

② BI-Lok double ferrule fittings : D

③ Fitting type : as shown in the product list(Pages 3 & 4)

④ Applicable tube/pipe size : as shown in Table 1

inch and metric series tube show nominal size

and plus M for metric series tubes

schedule series pipe shows actual OD

⑤ Nominal size of smaller end of Union type fittings

and Nominal size of Thread

: as shown in Table 1 & 2

⑥ Material : SS for Stainless steel

B for Brass

**Table 1. Applicable Tube/Pipe Size**

Inch Tube		Metric Tube		Schedule Pipe		
Nominal Size	OD inch	Nominal Size	OD mm	Nominal A	Nominal B	OD mm
1	1/16	2M	2	6A	1/8 B	10.5
2	1/8	3M	3	8A	1/4 B	13.8
3	3/16	4M	4	10A	3/8 B	17.3
4	1/4	6M	6	15A	1/2 B	21.7
5	5/16	8M	8			
6	3/8	10M	10			
8	1/2	12M	12			
10	5/8	15M	15			
12	3/4	16M	16			
14	7/8	18M	18			
16	1	20M	20			
		22M	22			
		25M	25			

**Table 2. Nominal Size of Thread**

Taper Thread		Parallel Thread	
Nominal Size	NPT Size	Nominal Size	NPT Size
1	NPT1/16	2	5/16-24
2	NPT1/8	3	3/8-24
4	NPT1/4	4	7/16-20
6	NPT3/8	5	1/2-20
8	NPT1/2	6	9/16-18
12	NPT3/4	8	3/4-16
16	NPT 1	10	7/8-14
		12	1 1/16-12
		14	1 3/16-12
		16	1 5/16-12
Nominal Size	ISO Thread	Nominal Size	ISO Thread
R1	R1/16		
R2	R1/8	G2	G1/8
R4	R1/4	G4	G1/4
R6	R3/8	G6	G3/8
R8	R1/2	G8	G1/2
R12	R3/4	G12	G3/4
R16	R 1	G16	G1

## BI-Lok Tube Fittings Product List

BI-Lok tube fitting as shown below could be supplied even of small quantities meeting to the customer's requirements in various fields of industries.

### Tube to Taper Female Pipe

DCT	MDCT	Male Connector	
DCTZ	MDCTZ	Bore Through Male Connector	
DSC	MDSC	Bulkhead Male Connector	
DSCZ		Bore Through Bulkhead Male Connector	
	MDCC	Male Long Connector	
DLN	MDLN	Male Elbow	
	MDLL	Male Long Elbow	
DTK	MDTK	Male Run Tee	
DTN	MDTN	Male Branch Tee	

### Tube to Taper Male Pipe

DSA	MDSA	Female Connector	
DSS	MDSS	Bulkhead Female Connector	
DLF	MDLF	Female Elbow	
DTF	MDTF	Female Run Tee	
DTH	MDTH	Female Branch Tee	

### Tube to Tube Union

DUA	MUA	Union	
DUAZ		Bore Through Union	
DUR	MDUR	Reducing Union	
DURZ	MDURZ	Bore Through Reducing Union	
DSU	MDSU	Bulkhead Union	
DSUZ	MDSUZ	Bore Through Bulkhead Union	
DSUR	MDSUR	Bulkhead Reducing Union	
DLA	MDLA	Union Elbow	
DLR	MDLR	Reducing Union Elbow	
DSL		Bulkhead Union Elbow	
DTA	MDTA	Union Tee	
DTAZ		Bore Through Union Tee	
DTR	MDTR	Reducing Union Tee	
DTRZ		Bore Through Reducing Union Tee	
DXA	MDXA	Union Cross	
	MDEA	Vent Plugged Union	
	MDET	Vent Plugged Union Tee	



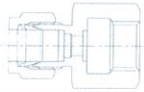
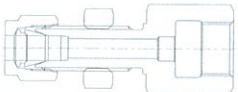
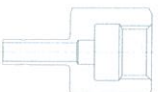

### Tube to Straight Female Thread

DUD	MDUD	Male Connector with Hose Adapter	
	MDLD	Male Elbow with Hose Adapter	
DLO	MDLO	Positional Male Elbow	
DCU	MDCU	O-ring seal Male Connector for Parallel Thread	
DCUZ		Bore Through O-ring seal Male Connector for Parallel Thread	
DCO	MDCO	O-ring Groove Male Connector for Parallel Thread	
DCM	MDCM	O-ring Groove Male Connector for Taper Thread	
DCF		O-ring seal Male Connector for Parallel Thread	
DCQ	MDCQ	Bonded seal Male Connector for Parallel Thread	
DCJ	MDCJ	Gasket seal Male Connector for Parallel Thread	
DCG		Gasket seal Male Connector for Parallel Thread	

### Tube to Pressure gauge

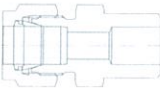
DGA	MDGA	Gauge Connector			
DGB	MDGB	Bulkhead Gauge Connector			
DHF	MDHF	Gauge Adapter			
DHG	MDHG	Gauge Adapter			

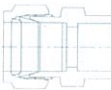
### Tube to Welded System

DCB	MDCB	Male Pipe Weld Connector				
DCBZ		Bore Through Male Pipe Weld Connector				
DLB	MDLB	Male Pipe Weld Elbow				
	MDTB	Male Pipe Weld Tee				
DCW	MDCW	Tube Socket Weld Connector				
DLW	MDLW	Tube Socket Weld Elbow				

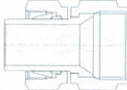
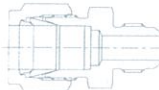
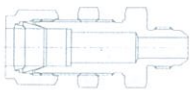

### 37° Flare Fitting to BI-Lok

DAN	MDAN	BI-Lok to AN Adapter			
DUC	MDUC	AN Union			
DUE	MDUE	AN Bulkhead Union			

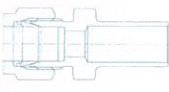
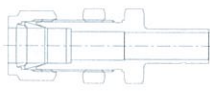
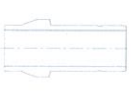
### Tube Connector to BI-Lok

DRE	MDRE	Reducer			
DREZ	MDREZ	Bore Through Reducer			
DSE	MDSE	Bulkhead Reducer			
DPC	MDPC	Port Connector			

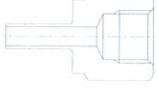
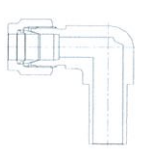
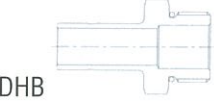



### Adapter for BI-Lok

DHA	MDHA	Male Adapter			
DHC	MDHC	Female Adapter			
DHO	MDHO	O-ring Groove Male Adapter for Parallel Thread			
DHB	MDHB	O-ring seal Male Adapter for Parallel Thread			
DHQ	MDHQ	Bonded seal Male Adapter for Parallel Thread			
DHJ	MDHJ	Gasket seal Male Adapter for Parallel Thread			
DLH	MDLH	Elbow Adapter			

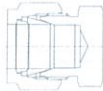

### Hose to Hose

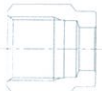
DAH		Hose Adapter			
DAT		Hose Adapter to NPT			
DTI		Insert(Saw Type)			

### Cap, Plug, Nut, Ferrules

DCA	MDCA	Cap					
DBA	MDBA	Plug					
DNA	MDNA	Nut					
DOF	MDOF	Front Ferrule					
DOB	MDOB	Back Ferrule					

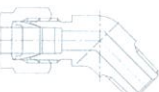
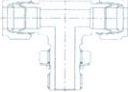
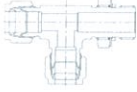
### Special Fittings

DMN		45° Male Elbow				
DTP		Positional Male Run Tee				
DTO		Positional Male Branch Tee				
DFC		Flanged Tube Connector				

## Material and Applicable Temperature for BI-Lok

Stainless steel :	-196 ~ 600 °C
Brass :	-196 ~ 150 °C

## Specification of Applicable Tube and Pipe

### a) Applicable Codes & Standards

#### 1) Stainless steel tube/pipe

- ① ASTM A 269, TP304, TP316
- ② JIS G 3459, SUS304TP, SUS316TP

#### 2) Brass tube/pipe

- ① ASTM B 68 class C10200, C10300, C10800, C12000, C12200
- ② ASTM B 75 class C10100, C10200, C10300, C10800, C12000, C12200, C14200
- ③ ASTM B 88 class C10200, C10300, C10800, C12000, C12200
- ④ JIS H 3300 class C1020, C1100, C1201, C1220

### b) Min. Wall Thickness

Minimum wall thickness of each size of tube / pipe is as shown in Table 3 and Table 4 for each series and material of tube / pipe.

### c) Tolerance of Outside Diameter (OD)

- 1) Stainless steel tube/pipe... Inch series(all sizes) :  $\pm 0.005$  inch( $\pm 0.13$ mm)  
Metric series(all sizes) :  $\pm 0.1$ mm  
Schedule series(all sizes) :  $\pm 0.1$ mm
- 2) Brass tube/pipe..... Inch series(all sizes) :  $\pm 0.002$  inch( $\pm 0.05$ mm)  
Metric series(all sizes) :  $\pm 0.05$ mm

### d) Tolerance of Wall Thickness

- 1)Stainless steel tube/pipe... Inch series:  $\pm 15\%$  for OD < 1/2"  
 $\pm 10\%$  for 1/2"  $\leq$  OD  $\leq$  1"  
Metric series(all sizes):  $\pm 10\%$   
Schedule series(all sizes):  $\pm 10\%$
- 2) Brass tube/pipe..... Inch series:  $\pm 0.0035$  inch( $\pm 0.09$ mm) for OD < 5/8"  
 $\pm 0.0045$  inch( $\pm 0.11$ mm) for 5/8"  $\leq$  OD  $\leq$  1"  
Metric series:  $\pm 0.08$ mm for OD  $\leq 15$ mm  
 $\pm 0.09$ mm for OD  $\geq 16$ mm

### e) Tolerance of OD Roundness(Max. OD—Min. OD): Max. 0.1mm for all sizes

### f) Surface Hardness

- 1) Stainless steel tube/pipe: Max. Hv 190(HRB90 max.)
- 2) Brass tube/pipe: Max. Hv 70

### g) Surface Condition : All tubes and pipes are free from any harmful dent, dirt, crack or roughness on their surfaces.

## Maximum Applicable Pressure

The maximum applicable pressure of Bi-Lok tube fittings shall be same as the maximum applicable pressure P(MPa) calculated by the FORMULA (1), which is specified in Para.304.1.2, ANSI/ASME B31.3-1996. is listed in Table 3 and 4 for each size, wall thickness, material and series.

$$\text{Formula(1) : } P(\text{MPa}) = 2t \times SE / (D - 2tY)$$

Applicable Temp.: -196~38°C for SS

-196~38°C for Brass

SE(N/mm<sup>2</sup>) : Permissible stress of tube/pipe

137.8(20,000psi) for SS

41.3(6,000psi) for Brass

D: Maximum OD(include tolerance)

t: Minimum wall thickness of tube/pipe

Y = 0.4 when t < D/6

Y = D-t when t ≥ D/6

**Table 3 : Maximum Applicable Pressure of SS Tube/Pipe (MPa)**

Inch Series

OD	Wall Thickness (Inch)				
	0.010	0.012	0.014	0.016	0.020
1/16	38.0	48.6	57.3	66.1	83.9

OD	Wall Thickness (Inch)											
	0.028	0.035	0.039	0.049	0.059	0.065	0.079	0.083	0.095	0.098	0.109	0.120
1/8	58.8	75.3	85.5									
3/16	37.7	48.9	55.5	71.0								
1/4	27.7	35.5	40.4	52.0	63.8	70.6						
5/16		28.0	31.7	40.6	49.9	55.6						
3/8		23.1	26.1	33.3	40.7	45.3						
1/2		18.1	20.5	26.0	31.7	35.2	43.6	46.3				
5/8				20.5	24.9	27.6	34.1	36.1	41.9	43.7		
3/4				17.0	20.6	22.7	28.0	29.6	34.3	35.7	40.0	
7/8				14.4	17.5	19.3	23.7	25.1	29.0	30.2	33.8	
1					15.2	16.8	20.6	21.8	25.1	26.1	29.2	32.4

Metric Series

OD	Wall Thickness (mm)							
	0.5	0.8	1.0	1.2	1.5	2.0	2.5	3.0
2 M	69.8							
3 M	45.3	6.4						
4 M	33.2	56.1	71.9					
6 M		35.9	46.1	56.6	72.6			
8 M		26.4	33.6	41.1	53.0			
10M		20.8	26.4	32.2	41.2			
12M		17.2	21.8	26.5	33.8	46.7		
15M				20.9	26.5	36.3	46.8	
16M				19.5	24.8	33.8	43.4	
18M				17.3	21.9	29.8	38.0	
20M				15.5	9.6	26.6	33.9	
22M					17.7	24.0	30.5	
25M					15.5	21.0	26.6	32.4

Schedule Series

OD		Wall Thickness (Inch)									
Nominal	mm	0.039	0.047	0.059	0.067	0.079	0.083	0.087	0.091	0.098	0.110
6 A 1/8 B	10.5	25.1	30.6	39.1	46.0						
8 A 1/4 B	13.8		22.8	29.0	33.3	39.8	42.0	44.3			
10A 3/8 B	17.3		18.0	22.8	26.1	31.1	32.8	34.5	36.2		
15A 1/2 B	21.7				20.5	24.4	25.7	27.0	28.3	31.0	35.1

## SPECIAL REQUIREMENTS OF MATERIAL FOR BI-Lok TUBE FITTINGS

Materials for BI-Lok tube fittings shall be in accordance with the specification of stainless steel or brass as shown in the Paragraph "Specification of Applicable Tube and Pipe" as the standard materials. Ihara Science Corporation will respond to customers who have special requirements for material such as Monel, Hastelloy. So please consult us if you have such special requirements on material of fittings.

**Table 4. Maximum Applicable Pressure(MPa) of Brass Tube/Pipe**  
Inch Series

OD	Wall Thickness (Inch)										
	0.028	0.035	0.039	0.049	0.059	0.065	0.079	0.083	0.095	0.098	0.109
1/8	18.6	24.6	27.9	35.3	44.8						
3/16	11.9	15.8	18.0	23.8	29.2						
1/4	8.7	11.5	13.6	17.4	21.6	24.1					
5/16		9.0	10.2	13.6	16.9	19.0					
3/8		7.4	8.4	11.1	13.8	15.5					
1/2		5.5	6.4	8.1	10.0	11.2	14.1	15.9			
5/8				6.3	7.8	8.7	10.9	11.5	13.5	14.0	
3/4				5.2	6.4	7.1	8.9	9.4	11.0	11.4	12.9
7/8				4.4	5.4	6.0	7.6	8.0	9.3	9.7	10.9

Metric Series

OD	Wall Thickness (mm)											
	0.3	0.4	0.5	0.6	0.8	1.0	1.2	1.5	2.0	2.5	2.75	3.0
2 M	9.7	14.2	15.2									
3 M	6.3	9.5	12.8	16.3	23.3							
4 M	4.7	7.0	9.1	11.8	17.0	22.3	27.6					
6 M	3.1	4.6	6.1	7.6	10.9	14.3	22.5					
8 M	2.3	3.4	4.5	5.6	8.0	10.4	14.1	16.9	23.5			
10M	1.8	2.7	3.6	4.5	6.3	8.2	10.1	13.1	18.5			
12M		2.2	3.0	3.7	5.2	6.7	8.3	10.7	15.1			
15M			2.4	2.9	4.1	5.3	6.5	8.4	11.7			
16M			2.2	2.7	3.8	4.9	6.0	7.8	10.9	14.1		
18M				2.4	3.4	4.3	5.3	6.8	9.5	12.3		
20M				2.1	3.0	3.9	4.8	6.2	8.5	11.0		
22M				1.9	2.7	3.5	4.3	5.6	7.7	9.9	11.0	
25M				1.7	2.4	3.1	3.8	4.9	6.7	8.6	9.6	10.1

**Table 5. Coefficient of Permissible Stress of Piping Materials**

Temperature °F	Tube/Pipe Materials		
	TP304	TP316	Copper
-321	100	100	100
32	100	100	100
100	100	100	100
200	100	100	80
300	100	100	78
400	94	97	50
500	88	90	
600	82	85	
650	81	84	
700	80	82	

\*The allowable stresses shown above are specified in ANSI/ASME B31.3 (Chemical Plant and Petroleum Refinery Piping-1980 for TP304 and 316 of ASTM A269 and for Copper of ASTM B75 Annealed material.)

\* Maximum Applicable Pressure at elevated temperatures shall be derated by multiplying Maximum Applicable Pressure at 32°F by the above coefficient/100.



## Assembly Instruction

Assembly BI-Lok as per Fig. 1.

a) At first, tube shall be cut square and end surface shall be deburred to prevent any damage on internal surface of BI-Lok.

b) Insert tube through nut so as to contact firmly on internal stop end of BI-Lok body

Take care for inserting tube straight to prevent any damage on internal surface of BI-Lok. (Fig. 2)

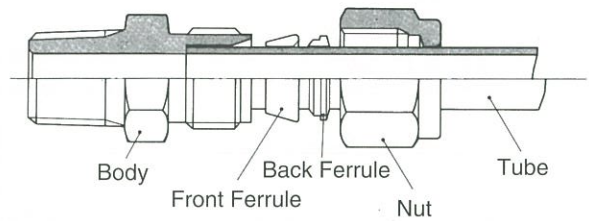

Fig. 1

c) Tighten nut with fingers as much as possible. This position is called as "Finger Tight Position" (FTP).

Put a mark on both body and nut to notice the finger tight position by a marker.

d) Holding hexagon of BI-Lok body rigidly by a spanner, screw nut tightly by a spanner as shown in the table below. (Fig. 3)

Fitting Size OD	Tightening from FTP
1/16" ~ 3/16", 2mm~4mm	3/4 turn
1/4" ~ 1", 6mm~25mm	1-1/4 turn
Plug, Port Connector	
1/16" ~ 3/16", 3mm~4mm	1/8 turn
1/4" ~ 1", 6mm~25mm	1/4 turn

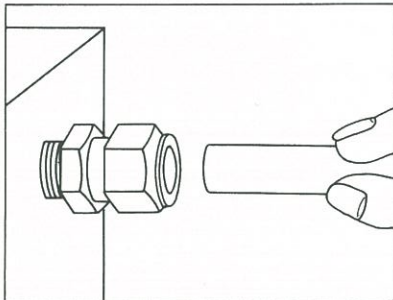

Fig. 2

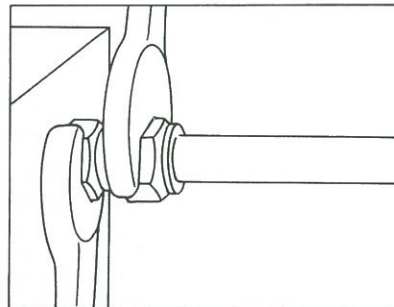

Fig. 3

Note: BI-Lok tube fittings are supplied in assembled condition, which are available for application as they are without any disassembling. If you disassemble BI-Lok tube fittings, please reassemble each part carefully for direction referring to Fig. 1.

## Instruction for Disassembly & Reassembly

a) When you disassemble BI-Lok tube fittings, put a mark on nut and body to notice the tightening position before disassemble nut.

b) When you reassemble nut, tight a little more from the marked position. If you repeat this sequence several times, BI-Lok tube fittings keep their tightness as of original state.

c) Tightness of BI-Lok tube fittings are secured even after 25 times of disassemble and reassemble tests. (increase of tightness: 15° from FTP)

## Identify Fitting Series

Metric Series and Inch Series have a LOGO Mark on forged part and Metric Series Machined Part has shoulders on body.

LOGO in Circle for Metric Series

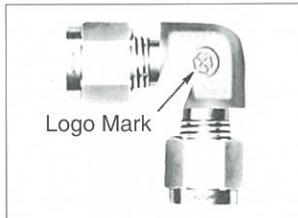

LOGO in Square for Inch Series

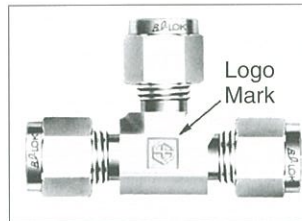

Shoulders for Metric Series Machined Part

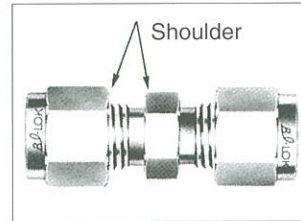

## How to Order

Please confirm BI-Lok's part number by referring the paragraph "Part Number / Order Number" or other Ihara's catalog.

### a) Expression of Different Sizes

For preventing a incorrect order of tube fittings having two or more sizes of OD, such as connectors, elbows, tees and crosses, please obey to the instruction for expression of different sizes of OD ①~④ as shown below.

Expression of Sizes	Layout of OD and its size	
① - ②	<p>① ————— ② Connectors, elbows</p>	<p>① : Bigger OD of run or Biggest OD of lines</p> <p>② : Smaller OD of run or Smaller OD on same line of ①</p> <p>③ : Branch OD or Bigger OD of sub-run(another line of ①)</p> <p>④ : Smaller OD on sub-run</p>
① - ② - ③	<p>① ————— ② tees            ③</p>	
① - ② - ③ - ④	<p>                  ③ ① ————— ② cross            ④</p>	

### b) Requirements for Materials

Standard material for BI-Lok tube fittings : SUS 316 and Brass (Consult for Hastelloy, Monel or others)

### c) Requirements for Cleaning

Please consult with Ihara for tube fittings according to special cleaning requirements such as those for a high purity gas piping system in semi-conductor manufacturing facilities .

### d) Please consult with Ihara for special tube fittings having the special corrosion resistance.

### e) Please consult with Ihara for special requirements of coloring identification on tube fittings.

## SPECIAL CAUTION

- Please note that brass tube fittings seem to be sensitive to stress corrosion cracking in the environment containing ammonium, oxygen and humidity simultaneously and also are sensitive to dezincing corrosion in piping system of water with salt or pure water, so please manage them carefully.
- Please disassemble nut and ferrules when you weld a BI-Lok tube fitting.

VALVES CONNECTING TO BI-LOK

	<p><b>VN Series Needle Stop Valve</b></p>	<p><b>VB Series Needle Stop Valve (Compact Type)</b></p>	
	<p><b>VQ Series Needle Stop Valve (Outside Screw Type)</b></p>	<p><b>VBM Series Fine Metering Stop Valve</b></p>	
	<p><b>VC Series Needle Stop Valve for Low Temp. Service</b></p>	<p><b>VH Series Needle Stop Valve for High Temp. Service (Outside Screw Type)</b></p>	
	<p><b>TVR Series Ball Valve for Multipurpose</b></p>	<p><b>BOFR Series Ball Valve Oil/Water Free</b></p>	
	<p><b>CV Series Bellows Valve</b></p>	<p><b>DV Series Diaphragm Valve</b></p>	
	<p><b>QJ Series Quick Joint</b></p>	<p><b>CH Series Check Valve</b></p>	

## ACCESSORIES AND PIPING

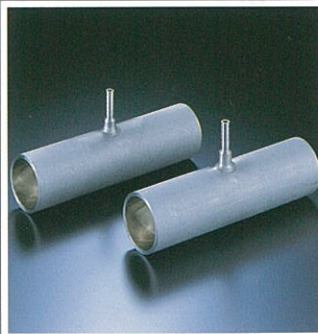

Branch Tube

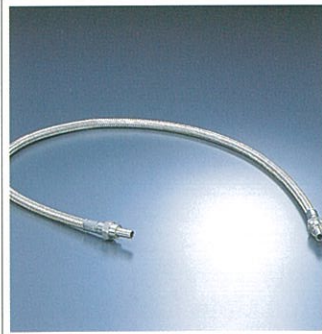

Flexible Hose



Pressure Tester



Tube Cutter

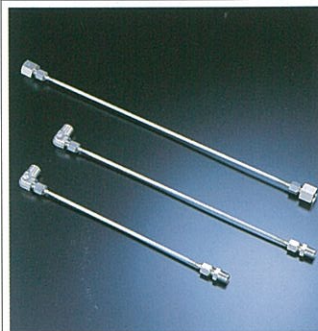

Capillary Tube



Leak Detector

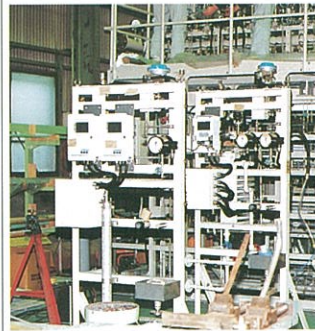

Semi-Fabricated  
Piping system



Piping Unit

**WARNING:** If you don't select and handle fittings, valves and related accessories in an adequate manner, it may damage human beings and applicable systems.  
Within the responsibility and authorization of users and piping designers, fittings, valves and related accessories shall be adequately selected, assembled, used and maintained based on the applicable conditions and product conformity to the system to be applied. Please read carefully our operation manual and feel free to contact with Ihara if you have any question or request.

## IHARA SCIENCE CORPORATION

URL: <http://www.ihara-sc.co.jp>

Head Office / 11-3 Takanawa 3-chome Minato-ku, Tokyo 108-0074 Japan  
Telephone. +81-(0)3-6721-6981 FAX. +81-(0)3-6721-6991