

# AL-31·31H

## Features

1. Safety relief valve of all stainless steel made, offering high corrosion resistance and durability in particular.
2. Popping structure ensures reliable discharge.

## Specifications

Model		AL-31	AL-31H
Structure		Closed type	
Application		Steam, Air, Cold and hot water, Oil, Other non-dangerous fluids	
Working pressure		0.05-1.0 MPa	1.0-2.0 MPa
Maximum temperature		220°C *	
Material	Valve case	Cast stainless steel	
	Spring case	Cast stainless steel	
	Valve, valve seat	Stainless steel	
Connection		JIS 10K RF flanged	JIS 16K RF flanged JIS 20K RF flanged

\* The maximum temperature is 150°C when using for water, oil, or other liquids.

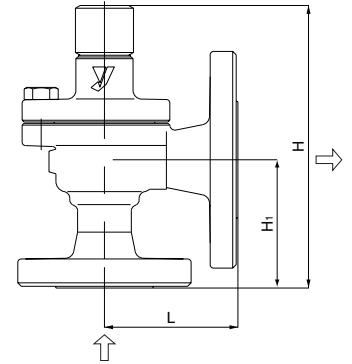

## Dimensions and Weights

Nominal size	Dimension (mm)					Flow area πDℓ (mm <sup>2</sup> )	Weight (kg)
	Inlet diameter x Outlet diameter	L	H <sub>1</sub>	H	Seat diameter		
15A	15 x 20	73	72	160	16	20.1	3.4
20A	20 x 25	77	74	163	21	34.6	4.5
25A	25 x 32	91	87	187	26	53.0	6.5
32A	32 x 40	96	92	238	33	85.5	8.1 ( 8.3)
40A	40 x 50	114	100	277	41	132.0	11.4 (11.7)
50A	50 x 65	116	107	315 (357)	51	204.2	15.0 (18.0)

• The above values in parentheses are the dimensions and weights of JIS 20K RF flanged.

## Certified Capacity Table

### ●For steam (saturation temperature) <Pressure vessel structure standard>

(kg/h)

Nominal size \ Pressure MPa	Pressure MPa																					
	0.05	0.1	0.2	0.3	0.4	0.5	0.6	0.7	0.8	0.9	1.0	1.0	1.1	1.2	1.3	1.4	1.5	1.6	1.7	1.8	1.9	2.0
15A	15	20	29	40	50	60	70	80	90	100	109	109	119	129	139	149	158	168	178	188	198	207
20A	27	35	51	69	87	104	121	138	155	172	189	189	206	222	239	256	273	290	306	324	340	357
25A	42	54	78	105	133	159	186	212	237	263	289	289	315	341	367	393	418	444	470	496	522	547
32A	67	87	127	170	215	257	300	342	383	425	467	467	509	550	592	634	675	716	758	800	842	883
40A	104	135	196	263	332	397	463	528	592	656	721	721	786	850	914	979	1042	1106	1171	1236	1300	1364
50A	161	209	303	407	513	615	716	817	916	1016	1116	1116	1216	1315	1414	1514	1612	1712	1811	1912	2011	2110

### ●For air (20°C) <Pressure vessel structure standard>

(kg/h)

Nominal size \ Pressure MPa	Pressure MPa																					
	0.05	0.1	0.2	0.3	0.4	0.5	0.6	0.7	0.8	0.9	1.0	1.0	1.1	1.2	1.3	1.4	1.5	1.6	1.7	1.8	1.9	2.0
15A	25	33	48	65	81	98	114	131	147	164	181	181	197	214	230	247	264	280	297	313	330	347
20A	44	57	83	111	140	169	197	226	254	283	311	311	340	368	397	426	454	483	511	540	568	597
25A	67	87	127	171	215	258	302	346	390	433	477	477	521	565	608	652	696	740	783	827	871	915
32A	108	141	205	276	347	417	488	558	629	699	770	770	841	911	982	1052	1123	1193	1264	1335	1405	1476
40A	168	218	317	426	535	644	753	862	971	1080	1189	1189	1298	1407	1516	1625	1734	1843	1952	2061	2170	2279
50A	259	338	491	660	828	997	1166	1334	1503	1671	1840	1840	2008	2177	2345	2514	2682	2851	3020	3188	3357	3525

### ●For water (accumulation: 25%) <Internal standard>

(m<sup>3</sup>/h)

Nominal size \ Pressure MPa	Pressure MPa																					
	0.05	0.1	0.2	0.3	0.4	0.5	0.6	0.7	0.8	0.9	1.0	1.0	1.1	1.2	1.3	1.4	1.5	1.6	1.7	1.8	1.9	2.0
15A	0.2	0.3	0.5	0.6	0.7	0.8	0.8	0.9	1.0	1.0	1.1	1.1	1.1	1.2	1.2	1.3	1.3	1.4	1.4	1.5	1.5	1.6
20A	0.4	0.6	0.8	1.0	1.2	1.3	1.5	1.6	1.7	1.8	1.9	1.9	2.0	2.1	2.2	2.3	2.3	2.4	2.5	2.6	2.6	2.7
25A	0.6	0.9	1.3	1.6	1.8	2.1	2.3	2.5	2.6	2.8	2.9	2.9	3.1	3.2	3.4	3.5	3.6	3.7	3.9	4.0	4.1	4.2
32A	1.0	1.5	2.1	2.6	3.0	3.4	3.7	4.0	4.3	4.5	4.8	4.8	5.0	5.2	5.5	5.7	5.9	6.1	6.2	6.4	6.6	6.8
40A	1.6	2.3	3.3	4.0	4.7	5.2	5.7	6.2	6.6	7.0	7.4	7.4	7.8	8.1	8.4	8.8	9.1	9.4	9.7	9.9	10.0	10.5
50A	2.5	3.6	5.1	6.3	7.2	8.1	8.9	9.6	10.3	10.9	11.5	11.5	12.0	12.6	13.1	13.6	14.1	14.5	15.0	15.4	15.8	16.3

• AL-31: 0.05-1.0 MPa AL-31H: 1.0-2.0 MPa

• Please contact us for the calculation procedure for nominal size selection.