

PF-2000 PUMPING TRAP

INSTRUCTION MANUAL

Thank you very much for choosing the Yoshitake's product. To ensure the correct and safe use of the product, please read this manual before use. This manual shall be kept with care for future references.

The symbols used in this manual have the following meanings.



	Warning	This symbol indicates a potentially hazardous situation that, if not avoided, could result in death or serious injury.
	Caution	This symbol indicates a hazardous situation that, if not avoided, may result in minor or moderate injury or may result in only property damage.

Table of Contents

1. Specifications	1
2. Dimensions and Weights	2
3. Structure	2
4. Operation	3
5. Flow rate	4
6. Installation	
6.1 Piping example	5
6.2 Warning and caution for installation	6-7
7. Operation procedure	
7.1 Warning and caution for operation	8
7.2 Operation method	8
8. Maintenance	
8.1 Warning and caution for maintenance/inspection	9
8.2 Daily and Periodic inspection/Periodic replacement	9-10
8.3 Troubleshooting	11-12
8.4 Disassembly/assembly method	12-18
9. Exploded view	19
Warranty Information	

YOSHITAKE

1. Specifications

Model	PF-2000	
Nominal size	25A	
Application	Steam condensate / Non-hazardous fluid	
Driving fluid	Steam / Air	
Max. working pressure	0.5 MPa	
Driving pressure	0.03 to 0.5 MPa	
Driving differential pressure	(Back pressure + 0.03 MPa) to 0.5 MPa	
Max. driving temperature	160°C	
Material	Body	Ductile cast iron
	Trim parts	Stainless steel
	Float (P)	Stainless steel
Connection	JIS Rc screwed	
Check valve at inlet side	Built-in (Swing type)	
Check valve at outlet side	Externally attached	

* The most appropriate maximum driving pressure is the back pressure + 0.1 to 0.2 MPa.

* Attach an optional check valve (SCV-2 or SCV-3) 25A on outlet side of the product.



Caution

Please confirm that the indications on the product correspond with the specifications of the ordered product model before use.

* If they are different, please contact us without using the product.

2. Dimensions and Weights

* The unit is mm.

Weight: 17 kg

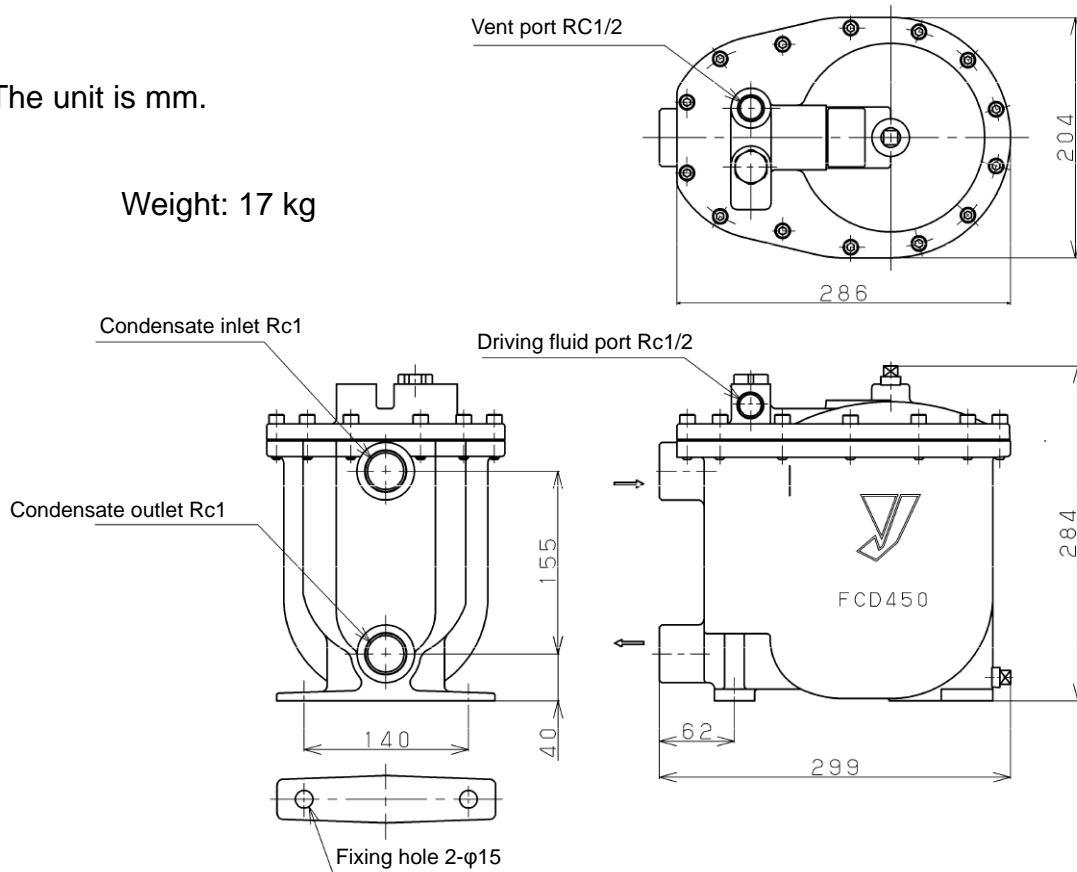

<<Connection diameter>>

Condensate inlet	Condensate outlet	Driving fluid port	Vent port
Rc1	Rc1	Rc1/2	Rc1/2

Fig. 1: Dimensions

3. Structure

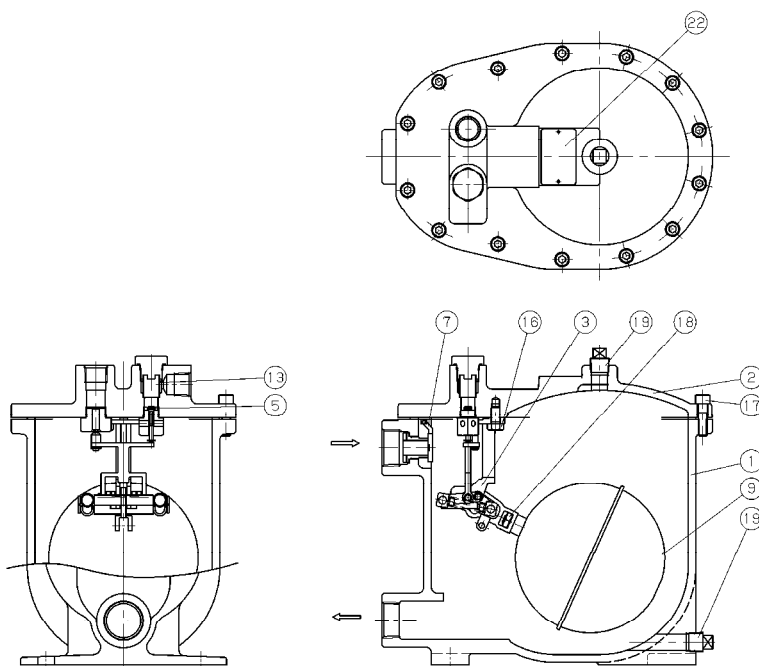

No.	Part name
1	Body
2	Cover
3	Valve (P)
5	Inlet valve
7	Check valve
9	Float (P)
13	Strainer
16	Hex bolt
17	Hex socket head cap bolt
18	Nut
19	Square head plug
22	Name Plate

Fig. 2: Structure

4. Operation

<State 1>

Condensate flows into body [1] via the condensate inlet and check valve [7], and float (P) [9] moves upward due to buoyancy. (See Fig. 3.)

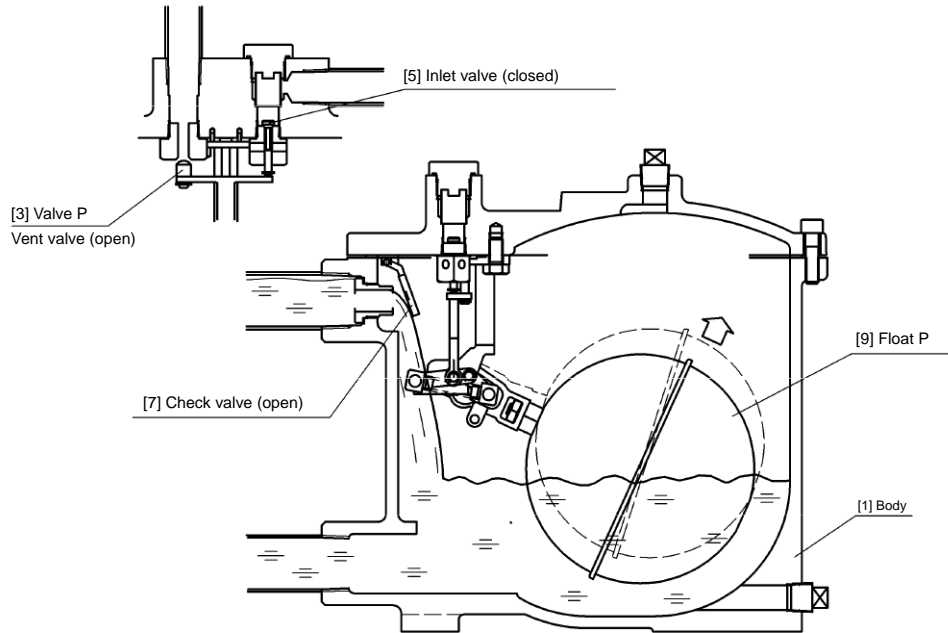

Fig. 3: State 1

<State 2>

When the condensate level rises and float (P) [9] reaches a certain height, inlet valve [5] is opened by valve (P) [3], and then vent valve of valve (P) [3] closes. The driving pressure enters body [1] following opening of inlet valve [5], closing check valve [7] and stopping the condensate flowing in. Condensate inside the body is transferred to the outlet side and discharged. When condensate is discharged, float (P) [9] moves downward in line with water level in the body. When it drops to a certain height, inlet valve [5] is closed and vent valve of valve (P) [3] opens. Internal pressure is released by vent valve, returning to state 1. (See Fig. 4.)

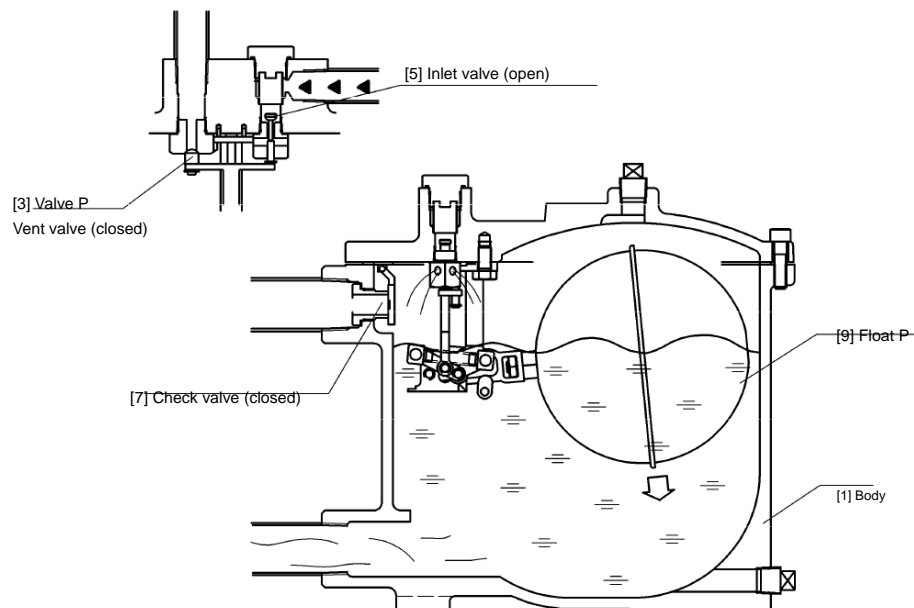

Fig. 4: State 2

5. Flow rate

(kg/h)

Driving pressure [MPa]	Back pressure [MPa]	Driven by steam	Driven by air
0.1	0.05	364	671
0.2		508	763
0.3		606	781
0.4		664	795
0.5		666	800
0.2	0.1	309	725
0.3		454	756
0.4		508	764
0.5		513	769
0.3	0.2	282	699
0.4		315	724
0.5		319	730
0.4	0.3	243	656
0.5		292	695
0.5	0.4	208	643

* Flow rate described above indicates condensate volume when height of the condensate inlet is 800 mm above bottom of the product. (6.1 Piping example)

Discharge capacity varies depending on height of the condensate inlet. Multiply the volume by the following factors according to the height of the condensate inlet.

* The height is the level above the bottom of the product

Driving fluid	Height of condensate inlet [mm]				
	600	800	1000	1200	1400
Steam	0.90	1.0	1.05	1.10	1.15
Air	0.85	1.0	1.15	1.25	1.35

6. Installation

6.1 Piping example

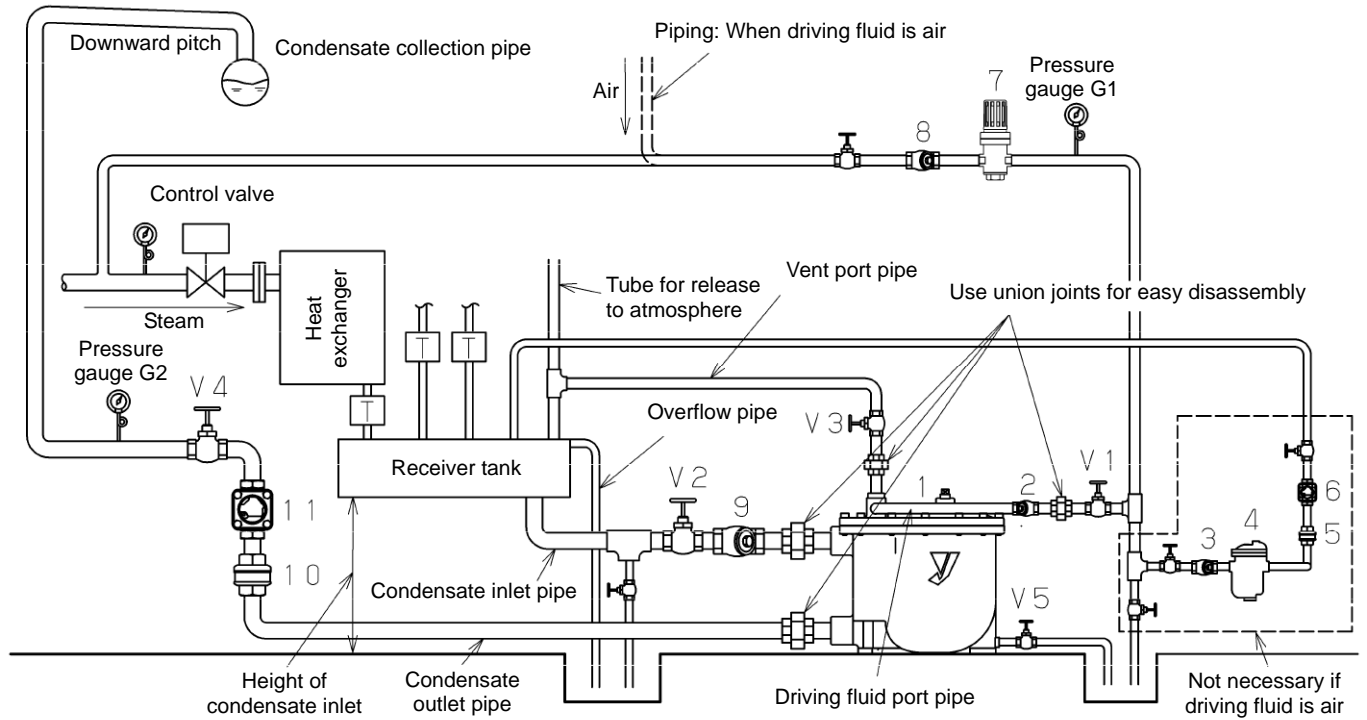

No.	Name	No.	Name	No.	Name
1	Pumping Trap PF-2000	6	Sight glass SL-1S 15A	11	Sight glass SL-1S 25A
2	Strainer SY-5 15A (80 mesh)	7	Pressure reducing valve GD-30 15A (GD-9N 15A if driving fluid is air)		
3	Strainer SY-5 15A (80 mesh)	8	Strainer SY-5 15A (80 mesh)		
4	Steam trap TB-20 15A	9	Strainer SY-5 25A (40 mesh)		
5	Check valve SCV-2 or 3 15A	10	Check valve SCV-2 or 3 25A		

6.2 Warning and caution for installation



Warning

1. Condensate may blow out of vent port following driving pressure drop or stop or failure of the product. Connect a pipe to the port and extend the pipe to a safe place.
* Failure to follow this notice may scald your skin by blowout of condensate.



Caution

1. Before installing the product, remove foreign substances and scale from the piping, and note that seal materials must not flow into the inside of the product or piping.
* Failure to follow this notice may hamper proper operation of the product.
2. Before connecting pipes, check the condensate inlet, condensate outlet, driving fluid port and vent port. (6.1 Piping example)
* The product does not function properly if piping is not connected correctly.
3. Install the product horizontally, with vent port facing upward.
* The product does not function properly if installation direction is not correct.
4. Connect the pipes firmly.
* Failure to follow this notice may cause burn injury by leakage of condensate from joints due to vibration.
5. Use union joints, etc. for connection with pipes. (6.1 Piping example)
* If union joints, etc. are not used, removal of pipes may become impossible or require more time in disassembly/assembly for maintenance/inspection.
6. Do not apply any shocks such as water hammer. Avoid using quick open/close valves near the product.
* Failure to follow this notice may cause burn injury by blowout of condensate caused by excessive shock on the product.
7. Do not disassemble the product unless necessary.
* Failure to follow this notice may hamper proper operation of the product.
8. Attach strainers in front of condensate inlet and driving steam port. (6.1 Piping example)
* If strainers are attached, the product may not function properly due to intrusion of dust, etc. into the product.
9. Be sure to attach check valve to condensate outlet to ensure condensate discharge capacity. Attach check valve in proper direction. (6.1 Piping example)
10. If driving fluid is steam, install a steam trap for condensate discharge to the pipe on driving fluid port. (6.1 Piping example)

11. Be sure to secure maintenance space needed for disassembly and repair of the product.
(See Fig. 5)
* The unit is mm.

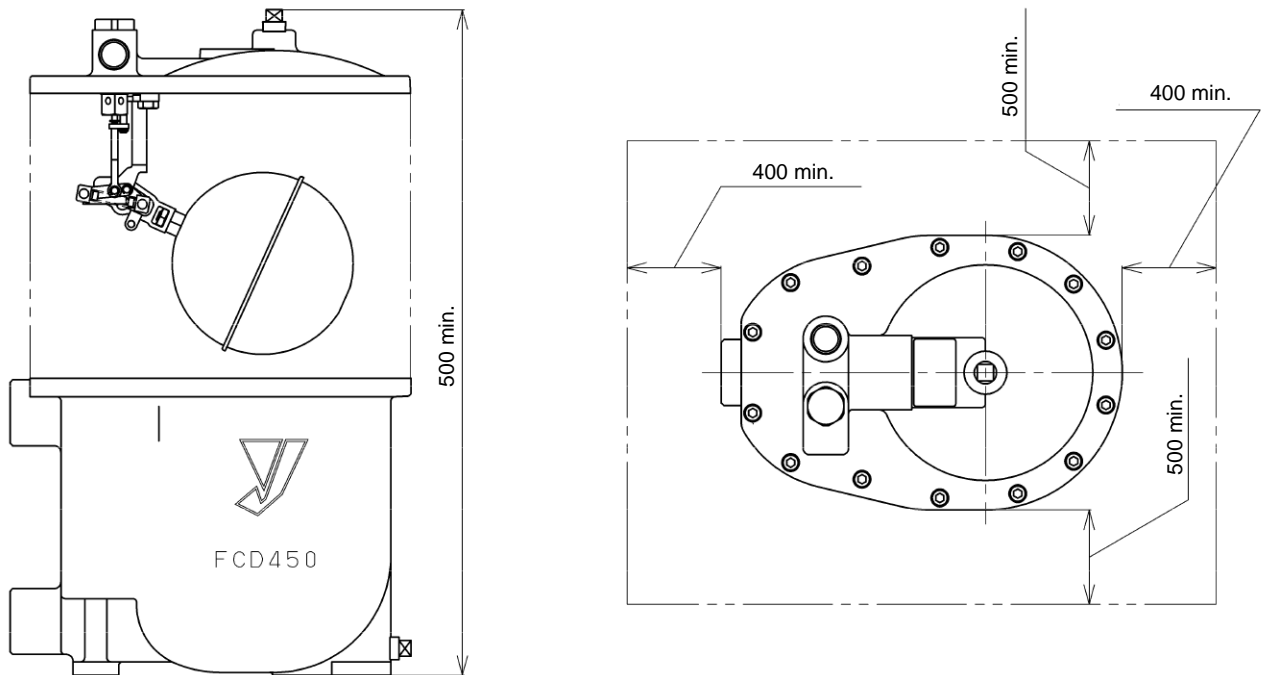

Fig. 5: Maintenance space

12. Recommended height of the condensate inlet is 800 mm or more. (6.1 Piping example)
13. Be sure to attach an overflow pipe to the receiver tank and lead the pipe to a safe place. (6.1 Piping example)
14. Please contact us if using for closed system.

7. Operation procedure

7.1 Warning and caution for operation

Warning

1. Do not touch the product by bare hands when steam is flowing.
* Failure to follow this notice may cause burn or injury.
2. Confirm that pipe joints are connected firmly and not unstable before letting the steam flow.
* Failure to follow this notice may cause blowout of steam or condensate, resulting in scalds..

Caution

1. Open stop valves on pipes slowly to prevent water hammer.
* Sudden opening of stop valves may cause hunting or water hammer, damaging the devices.
2. The product is activated by driving pressure. If driving pressure is lower than back pressure on the outlet side, condensate continues to flow into the product and the product will be filled with condensate. Under this situation, driving pressure port is blocked by condensate and condensate cannot be pushed out by driving pressure. Therefore, if driving fluid is steam, be sure to confirm that sufficient pressure exists in driving steam line using pressure gauge G1 before start of operation. (6.1 Piping example)
* Actions to be taken when the product is filled with condensate fully
Close valve V1 on driving steam line and valve V2 at condensate inlet first, and then open blow valve V5 at the bottom of the product for drainage. (6.1 Piping example)

7.2 Operation method

See 6.1 Piping example for marks and numbers of stop valves. Stop operation immediately when water hammer occurs, and close stop valves in operation.

- 1: Open stop valve V4 at condensate outlet slowly until it is full open.
- 2: Open stop valve V3 at vent port slowly until it is full open.
- 3: Open stop valve V1 at driving fluid port slowly until it is full open.
- 4: Confirm by pressure gauge G1 that driving pressure is sufficient, and then open stop valve V2 at condensate inlet slowly until it is full open.
- 5: If the product is activated and transfer of condensate is confirmed through sight glass 11, start up operation is completed.

8. Maintenance

Most failures of the product are caused due to foreign materials in the pipes. Be especially careful to foreign materials in the pipes. We charge for repair of product failures caused by catching of foreign materials at the customer's site.

8.1 Warning and caution for maintenance and inspection

Warning

1. When performing periodic inspection or part replacement, be sure to confirm that pressure inside the product and pipes is equivalent to atmospheric pressure. Cool down the body of the product until it can be touched by bare hands. Inspection/replacement should be done by skilled experts (staff of facility management/engineering companies, etc.).
 - * Failure to follow this notice may result in injury by residual pressure in the product or pipes. If the temperature is high, it may result in scalds.
2. If leakage from the joint between the body and cover is observed, replace the gasket with a new one, without re-tightening hex socket head cap bolts.
 - * Re-tightening of hex socket head cap bolt may damage the gasket, causing steam blowout and scalds.

Caution

1. Perform periodic inspection to maintain functions and performance of the product.
 - * General users should ask experts (staff of facility management/engineering companies, etc.) to perform periodic inspection.
2. After leaving the product not operated for a long period, perform periodic inspection before start-up of operation. After periodic inspection, start operation again according to "7. Operation procedure."
 - * Failure to follow this notice may cause malfunction due to rust generated inside the product or pipes.

8.2 Daily and Periodic inspection/Periodic replacement

Perform daily and periodic inspection, periodic replacement to maintain functions and performance of the product.

8.2.1 Daily inspection

Inspect the following items once a day. (6.1 Piping example)

Items	How to inspect	Remedy
Driving pressure	Confirm that the pressure is 0.5 MPa or less using pressure gauge G1.	Control driving pressure by adjusting pressure reducing valve 7.
Condensate discharge condition	Perform visual check by sight glass 11.	If condensate is not discharged, see "8.3 Troubleshooting".
Outside leakage	Confirm by visual check.	See "8.3 Troubleshooting".

8.2.2 Periodic inspection

Check the following items once a year, in addition to daily inspection items. (See Fig. 6 for the numbers inside the brackets [].)

Items	How to inspect	Remedy	Actions to be taken
Float (P) [9] switching operation	<ol style="list-style-type: none"> 1. Close all stop valves in pipes that are connected to the product. 2. Remove square head plug (R3/8) [19] from the cover and forcibly let water flow in from there. 3. Confirm the “click” noise generated when valve (P) [3] is switched. 4. Remove square head plug (R3/8) [19] from the bottom of the body and forcibly let water flow out from there. 5. Confirm the “click” noise generated when valve (P) [3] is switched. 	If not switched, replace valve (P) [3] and float (P) [9].	See 8.4.4.
Clogging of strainer [13]	Disassemble and confirm by visual check.	* If the strainer is clogged, clean or replace it.	See 8.4.4.

8.2.3 Periodic replacement

The following parts should be replaced at recommended intervals to maintain functions and performance of the product. Replace the parts at the recommended intervals.

 Caution							
<p>1. Replace the parts periodically at the recommended intervals.</p> <p>* Failure to perform periodic part replacement may cause malfunction of the product.</p> <p>● List of parts to be replaced periodically</p> <table border="1" style="margin-left: 20px; border-collapse: collapse; width: 60%;"> <thead> <tr> <th style="text-align: center;">Part name</th> <th style="text-align: center;">Recommended replacement intervals</th> </tr> </thead> <tbody> <tr> <td style="text-align: center;">Valve (P)</td> <td>2 years or 100,000 cycles of operation, whichever is earlier</td> </tr> <tr> <td style="text-align: center;">Float (P)</td> <td>2 years or 100,000 cycles of operation, whichever is earlier</td> </tr> </tbody> </table>		Part name	Recommended replacement intervals	Valve (P)	2 years or 100,000 cycles of operation, whichever is earlier	Float (P)	2 years or 100,000 cycles of operation, whichever is earlier
Part name	Recommended replacement intervals						
Valve (P)	2 years or 100,000 cycles of operation, whichever is earlier						
Float (P)	2 years or 100,000 cycles of operation, whichever is earlier						
<p>2. Be careful to prevent dropping of parts in disassembly. Put disassembled parts on a soft cloth to prevent scratching.</p> <p>* If parts are scratched, malfunction may occur, resulting in functional deterioration.</p> <p>3. Be sure to replace with specified parts. Never remodel the product.</p> <p>* Failure to follow this notice may cause scalds or injury due to breakage of the product, blowout of steam or condensate, or abnormal behavior.</p> <p>4. Do not use old parts again after replacement.</p> <p>* If such old parts are used by mistake, malfunction may occur.</p>							

8.3 Troubleshooting (See 6.1 Piping example for marks and numbers of stop valves, and see Fig. 6 for the numbers inside the brackets [].)

Trouble	Cause	Remedy
Condensate is not discharged.	Stop valve V2 at condensate inlet is closed.	Open stop valve V2.
	Pipes at condensate inlet and condensate outlet are connected the other way around.	Connect the pipes correctly. (6.1 Piping example)
	Pipes at driving pressure inlet and discharge port are connected the other way around.	Connect the pipes correctly. (6.1 Piping example)
	Strainer 9 at condensate inlet is clogged.	Disassemble strainer 9 and clean the screen.
	Stop valve V4 at condensate outlet is closed.	Open stop valve V4.
	Stop valve V3 on Vent port pipe is closed.	Open stop valve V3.
	Driving pressure is too low to resist back pressure.	Control the pressure to a specified level by adjusting reducing valve 7.
	Stop valve V1 on pipe at driving fluid port is closed.	Open stop valve V1.
	Strainer 2 on pipe at driving fluid port is clogged.	Disassemble strainer 2 and clean the screen.
	Driving pressure exceeds the specified range.	Adjust driving pressure according to specifications. (See 1. Specifications.)
	Check valve V10 at condensate outlet is installed in opposite direction. Or the valve does not open.	If in opposite direction, install in proper direction. Replace if it does not open.
	Strainer [13] of the product is clogged.	Disassemble strainer [13] and clean it. (See Fig.8.4.4.)
	Leakage from vent valve at valve (P) [3].	Disassemble the product, and perform cleaning if the trouble is caused by scales in vent valve of valve (P) [3]. If the trouble is caused by scratches, etc. on the part, replace valve (P). (See Fig.8.4.4.)
	Check valve [7] is stuck and does not open. The valve does not close completely due to intrusion of foreign substance.	Confirm that no pressure exists in the product, disassemble the product, and clean check valve [7]. (See Fig.8.4.4.)
Leakage of steam from a set of inlet valves [5] and [6].	Disassemble the products and replace a set of inlet valves [5] and [6]. (See Fig.8.4.4.)	
Float (P) [9] is broken.	Disassemble the products and replace Float (P) [9]. (See Fig.8.4.4.)	

Trouble	Cause	Remedy
Leakage of steam to external area of the product.	Leakage from gasket [20] between body and cover.	Replace gasket [20]. (See Fig.8.4.4.)
	Leakage from strainer gasket [15].	Replace strainer gasket [15]. (See Fig.8.4.4.)
	Leakage from square head plug [19].	Remove square head plug [19], replace seal tape with a new one and fit the plug again.

8.4 Disassembly/assembly methods

8.4.1 Warning and caution for disassembly/assembly

 Warning
<p>1. Be sure to release internal pressure of the product, pipes and devices completely and cool down the product before disassembly and inspection. Do not touch the product by bare hands until it is cooled down completely.</p> <p>* Failure to follow this notice may cause injury or burn by residual pressure.</p>

 Caution
<p>1. Use a container to receive condensate that flows out when performing disassembly.</p> <p>* Failure to follow this notice may stain peripheral devices by condensate.</p> <p>2. Confirm that seats including valve seats are free from scratches, dents and stains. Clean if stained. Replace scratched, dented parts.</p> <p>* They may cause malfunction.</p> <p>3. In assembly, fit parts firmly and tighten bolts evenly and diagonally to prevent uneven torque.</p> <p>* Loose fitting and uneven tightening may cause malfunction or external leakage.</p> <p>4. Be sure to use specified parts to repair the product. Never remodel the product.</p> <p>* Failure to follow this notice may cause scalds or injury due to breakage of the product, blowout of steam or condensate, or abnormal behavior.</p> <p>5. Replace gaskets with new ones at the time of assembly.</p> <p>* They are consumables. Using old, replaced gaskets again may cause external leakage.</p>

8.4.2 Disassembly method (See Fig.6)

Tools used

Name of tool	Details (size, nominal size, etc.)
Wrench	13 mm, 17 mm, 24 mm
Adjustable wrench	Jaw opening: 0 to 25 mm
Box wrench	19 mm, 27 mm
Hex socket wrench	Width across flats: 6 mm
Ratchet handle	Used with hex socket wrench.

Procedure 1: Remove strainer cover [14] using box wrench (Width across flats: 27 mm), and then remove strainer [13] (cylindrical) and strainer gasket [15].

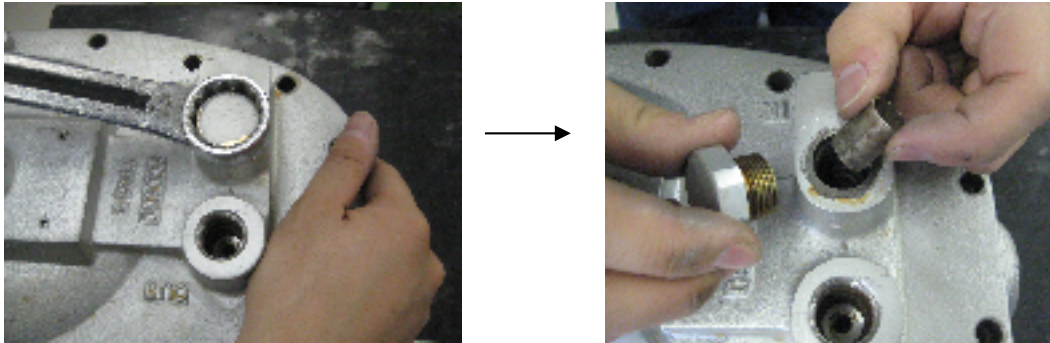

Procedure 2: Remove hex socket head cap bolt [17] by using hex wrench attached to ratchet handle, lift up the cover to remove cover [2] and gasket [20] from body [1].

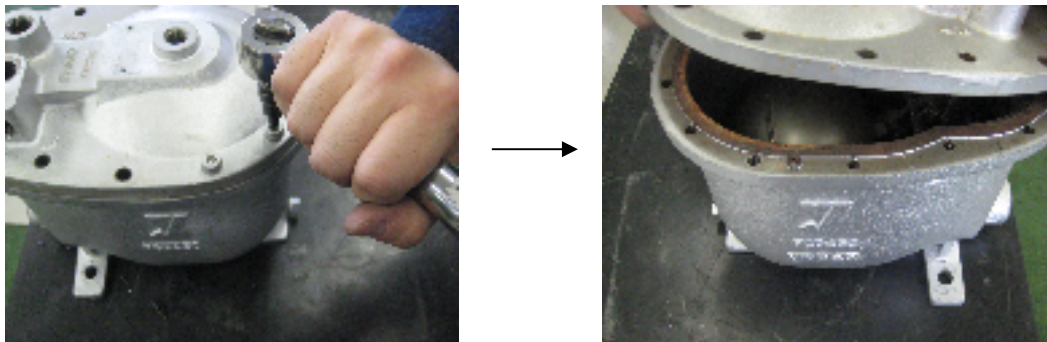

Procedure 3: Fix float arm of valve (P) [3] with the adjustable wrench, fit a wrench (width across flats: 17 mm) on hexagonal part of float (P) [9], and remove float (P). Nut [18] is in float arm. This nut is needed for assembly of float (P) [9].

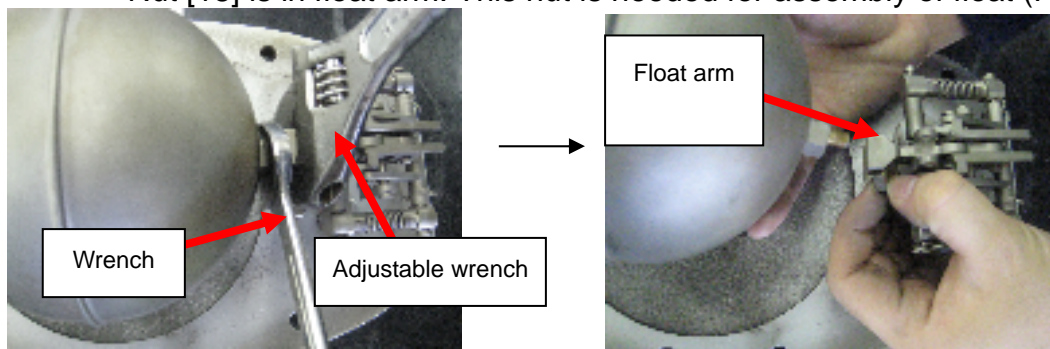

Procedure 4: Remove 2 hex bolts [16] from the cover, using a wrench (width across flats: 13 mm), and remove valve (P) [3].

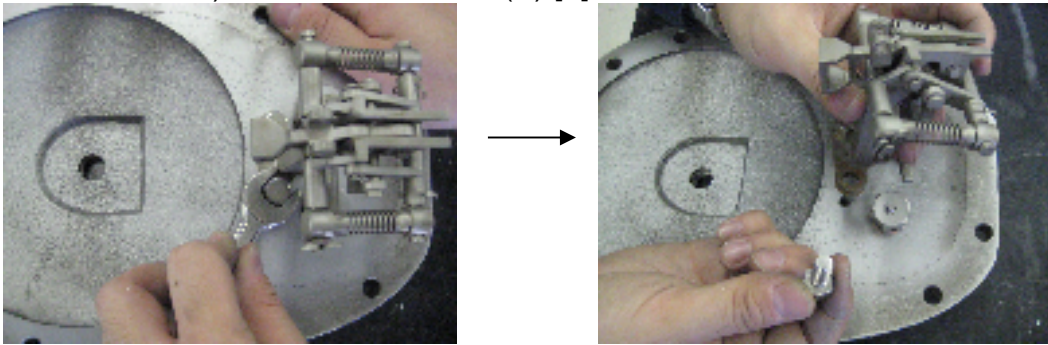

Procedure 5: Remove a set of inlet valves [5] and [6], using a box wrench (width across flats: 19 mm), and remove inlet valve seat gasket [10] at the same time.

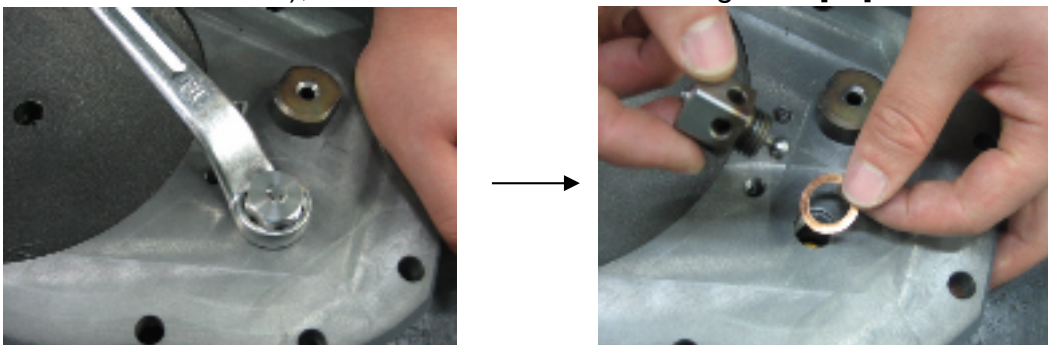

Procedure 6: Remove vent valve seat [4], using a wrench (width across flats: 24 mm), and remove vent valve seat gasket [11] at the same time.

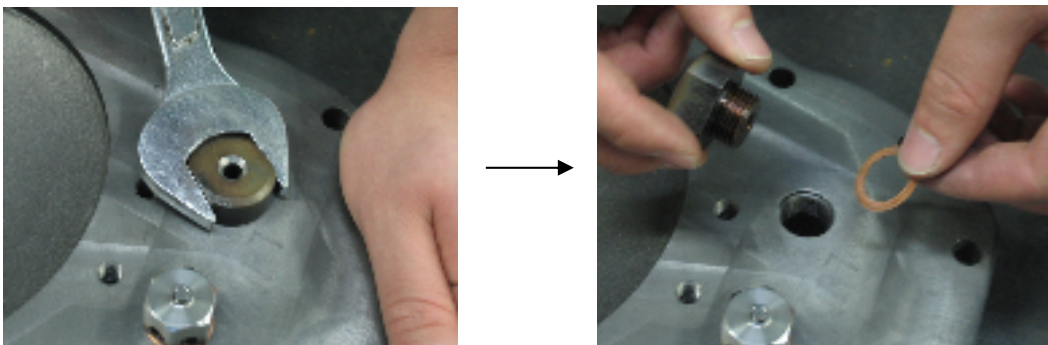

Procedure 7: Remove check valve [7] from body [1] by hand.



8.4.3 Assembly method (See Fig.6)

*Tools used

Name of tool	Details (size, nominal size, etc.)
Torque wrench	Any of those that can apply 35 N•m torque (Hex socket wrench is used)
Open end torque wrench	Width across flats of wrench: 17 mm, any of those that can apply 15 N•m torque
	Width across flats of wrench: 19 mm, any of those that can apply 50 N•m torque
	Width across flats of wrench: 24 mm, any of those that can apply 80 N•m torque
Wrench	13 mm
Box wrench	27 mm
Adjustable wrench	Jaw opening: 0 to 25 mm
Hex socket wrench	Width across flats: 6 mm

Procedure 1: Attach check valve [7] to body [1]. A check valve needs to be installed in the proper direction. Install the valve so that the processed side (with a dent in the center) will be oriented toward the screw.

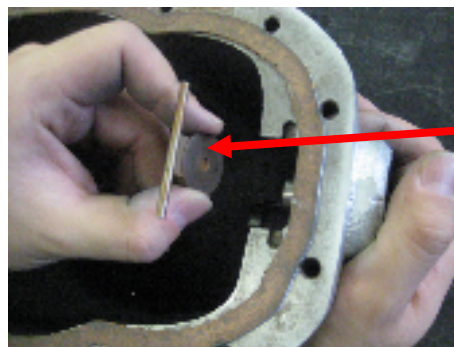

Processed surface
(dented surface)

Procedure 2: Assemble vent valve seat [4] and vent valve seat gasket [11] to cover [2]. Apply lubricant (machine oil) to the vent valve seat gasket and assemble it to the vent valve seat, and tighten the vent valve seat at 80 N•m torque using an open end torque wrench (width across flats: 24 mm).



Open end torque wrench
(Width across flats: 24 mm)

Procedure 3: Assemble a set of inlet valves [5] and [6] and inlet valve seat gasket [10] to cover [2]. Apply lubricant (machine oil) to the inlet valve seat gasket and assemble it to a set of inlet valves, and tighten the set of inlet valves at 50 N•m torque using an open end torque wrench (width across flats: 19 mm).

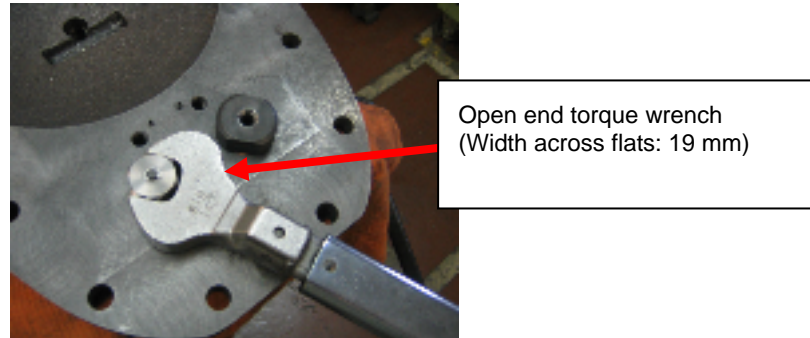

Procedure 4: When assembling valve (P) [3] to cover [2], fit valve (P) in alignment with two pins on the cover and tighten 2 hex bolts [16], using a wrench (width across flats: 13 mm).

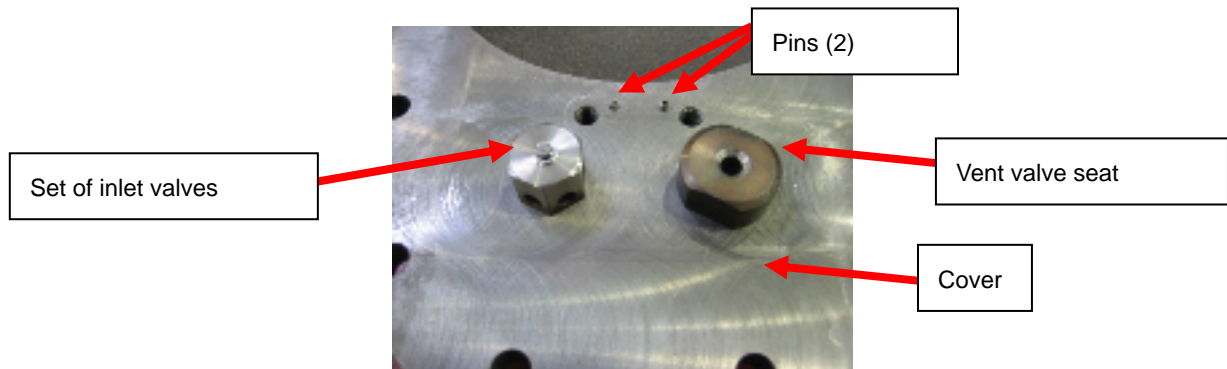

Procedure 5: Assemble float (P) [9] to valve (P) [3]. Put nut [18] in float arm, fix the float arm with an adjustable wrench, tighten the hexagonal portion (width across flats: 17 mm) of float (P) at 15 N•m torque using an open end torque wrench.

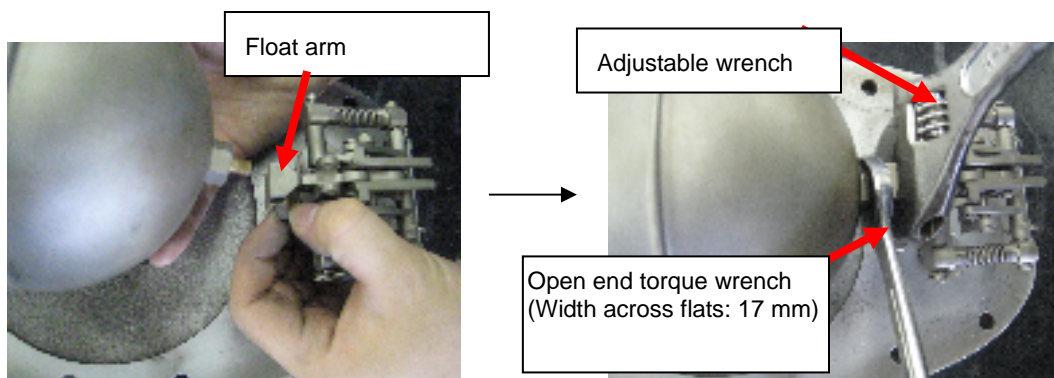

Procedure 6: Replace gasket [20] with a new one. Before assembling new gasket, apply paste on entire surface (including inner circumference).
(Recommended paste: SOLVEST110 manufactured by STT Inc.)

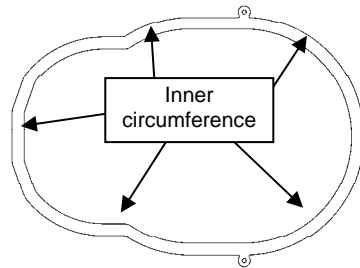

Procedure 7: Attach a new gasket to body [1]. Confirm that it matches two pins on the body.

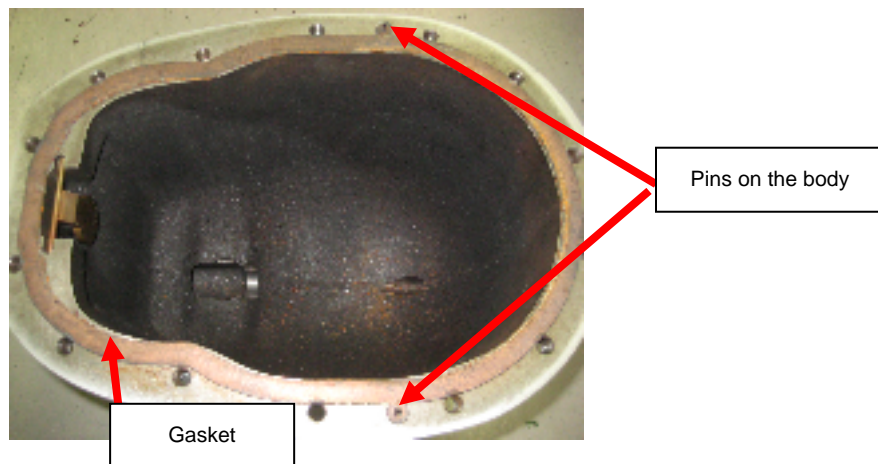

Procedure 8: Attach cover [2] to body [1]. Tighten hex socket head cap bolts [17] at 35 N•m torque using a torque wrench with a hex socket head (width across flats: 6 mm).

- * Confirm that cover [2] is firmly attached to two pins on body [1] before tightening hex socket head cap bolts [17]. If it is not firmly attached, damage to the pins or defective assembly could occur.
- * Do not use an L-type hex wrench for tightening the bolts. Use of an L-type hex wrench may cause damage to hexagonal opening or defective assembly due to insufficient tightening.

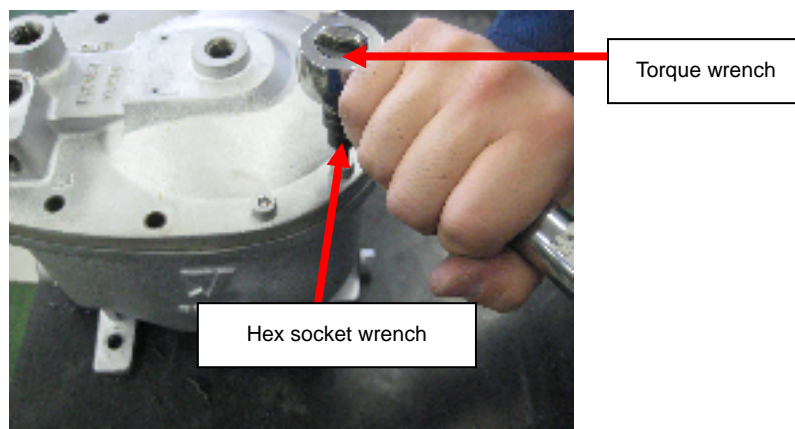

Procedure 9: Attach strainer [13] (cylindrical), strainer gasket [15] and strainer cover [14] to cover [2]. Put the strainer and strainer gasket in strainer cover, and screw them into the cover using a box wrench (width across flats: 27 mm).

8.4.4 How to replace each part

- How to replace gasket
Disassemble the gasket according to procedure 2 in “8.4.2 Disassembly method”, and replace and assemble it according to procedure 6 to 8 in “8.4.3 Assembly method”.

- How to replace float (P)
Disassemble the float according to procedure 2 and 3 in “8.4.2 Disassembly method”, and replace and assemble it according to procedure 5 to 8 in “8.4.3 Assembly method”.

- How to replace valve (P)
Disassemble the valve according to procedure 2 to 4 in “8.4.2 Disassembly method”, and replace and assemble it according to procedure 4 to 8 in “8.4.3 Assembly method”.

- How to replace a set of inlet valves
Disassemble the set of inlet valves according to procedure 2 to 5 in “8.4.2 Disassembly method”, and replace and assemble according to procedure 3 to 8 in “8.4.3 Assembly method”.

- How to replace vent valve seat
Disassemble the vent valve seat according to procedure 2 to 4 and 6 in “8.4.2 Disassembly method”, and replace and assemble the set according to procedure 2 and 4 to 8 in “8.4.3 Assembly method”.

- How to replace check valve
Disassemble the check valve according to procedure 2 and 7 in “8.4.2 Disassembly method”, and replace and assemble it according to procedure 1 and 6 to 8 in “8.4.3 Assembly method”.

- How to replace strainer, strainer gasket
Disassemble the strainer and strainer gasket according to procedure 1 in “8.4.2 Disassembly method”, and replace and assemble them according to procedure 9 in “8.4.3 Assembly method”.

9. Exploded view

*(Enclosed parts are offered as consumables.)

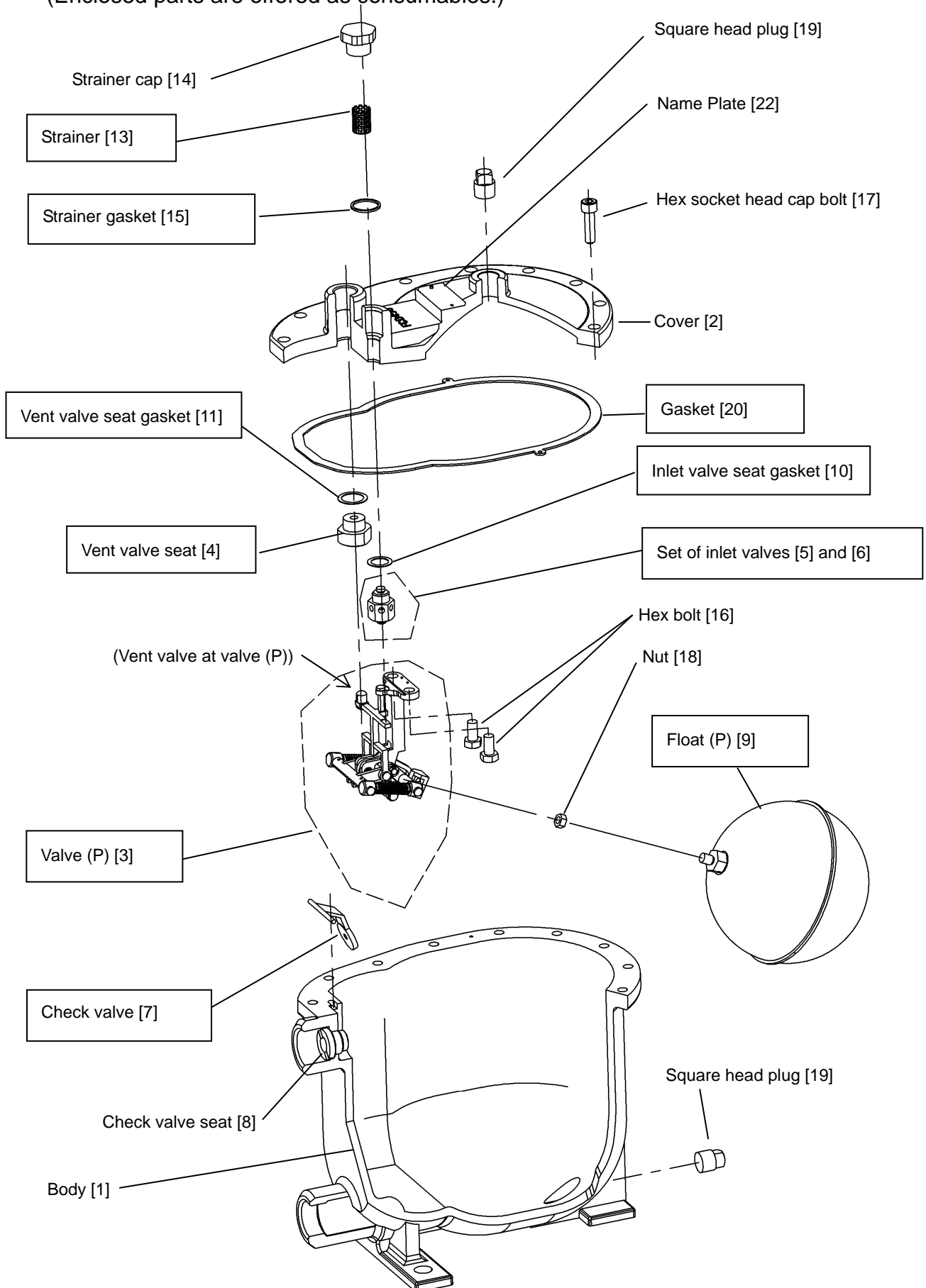

Fig. 6. Exploded view

Warranty Information

1. Limited warranty

This product has been manufactured using highly-advanced techniques and subjected to strict quality control. Please be sure to use the product in accordance with instructions on the manual and the label attached to it.

Yoshitake warrants the product to be free from any defects in material and workmanship under normal usage for a period of one year from the date of receipt by the original user, but no longer than 24 months from the date of shipment from Yoshitake's factory.

2. Parts supply after product discontinuation

This product may be subject to discontinuation or change for improvement without any prior notice. After the discontinuation of the product, Yoshitake supplies the repair parts for 5 years otherwise individually agreed.

3. This warranty does not cover the damage due to any of below:

- (1) Valve seat leakage or malfunction caused by foreign substances inside piping.
- (2) Improper handling or misuse.
- (3) Improper supply conditions such as abnormal water pressure/quality.
- (4) Water scale or freezing.
- (5) Trouble with power/air supply.
- (6) Any alteration made by other than Yoshitake.
- (7) Use under severe conditions deviating from the design specifications (e.g. in case of corrosion due to outdoor use).
- (8) Fire, flood, earthquake, thunder and other natural disasters.
- (9) Consumable parts such as O-ring, gasket, diaphragm and etc.

Yoshitake is not liable for any damage or loss caused by malfunction or defect of the product.

YOSHITAKE

INTERNATIONAL DEPT.

955-5, Miyamae, Irukadeshinden, Komaki, Aichi, 485-0084, Japan

Phone: +81-568-75-4432 Fax: +81-568-75-4763

E-mail: Intntl@yoshitake.co.jp