

PF-7000 PUMPING TRAP

INSTRUCTION MANUAL

Thank you very much for choosing the Yoshitake's product. To ensure the correct and safe use of the product, please read this manual before use. This manual shall be kept with care for future references.

The symbols used in this manual have the following meanings.



	Warning	This symbol indicates a potentially hazardous situation that, if not avoided, could result in death or serious injury.
	Caution	This symbol indicates a hazardous situation that, if not avoided, may result in minor or moderate injury or may result in only property damage.

Table of Contents

1. Specifications	1
2. Dimensions and Weights	2
3. Structure	2
4. Operation	3
5. Flow rate	4
6. Installation	
6.1 Piping example	5-6
6.2 Warning and caution for installation	7-8
7. Operation procedure	
7.1 Warning and caution for operation	9
7.2 Operation method	9
8. Maintenance	
8.1 Warning and caution for maintenance and inspection	10
8.2 Daily and Periodic inspection/Periodic replacement	
8.2.1 Daily inspection	10
8.2.2 Periodic inspection	11
8.2.3 Periodic replacement	11
8.3 Troubleshooting	12-13
8.4 Disassembly/assembly method	
8.4.1 Warning and caution for disassembly/assembly	13
8.4.2 Disassembly method	14-15
8.4.3 Assembly method	16-18
8.4.4 How to replace each part	19
9. Exploded view	20
Warranty Information	

YOSHITAKE

1. Specifications

Model	PF-7000	
Nominal size	25A (Condensate inlet: 25A / Condensate outlet: 25A) 40A (Condensate inlet: 40A / Condensate outlet: 40A) 50A (Condensate inlet: 50A / Condensate outlet: 50A) 80A (Condensate inlet: 80A / Condensate outlet: 50A)	
Application	Steam condensate / Non-hazardous fluid	
Driving fluid	Steam / Air	
Max. driving pressure	0.8 MPa *1	
Max. working temperature	180°C	
Material	Body	Ductile cast iron
	Trim parts	Stainless steel
	Float (P)	Stainless steel
Connection	JIS Rc screwed	
Check valve at inlet side	Externally attached *2	
Check valve at outlet side	Externally attached *2	

*1 The most appropriate value of driving pressure is back pressure at outlet side + 0.1 to 0.2 MPa.

*2 Attach an optional check valve (SCV-2 or SCV-3) on inlet and outlet side of the product.



Caution

Please confirm that the indications on the product correspond with the specifications of the ordered product model before use.

* If they are different, please contact us without using the product.

2. Dimensions and Weights

* Bush is attached at condensate inlet for the product of size 50A, and at condensate inlet and outlet for size 40A or less.

* The unit is in mm.

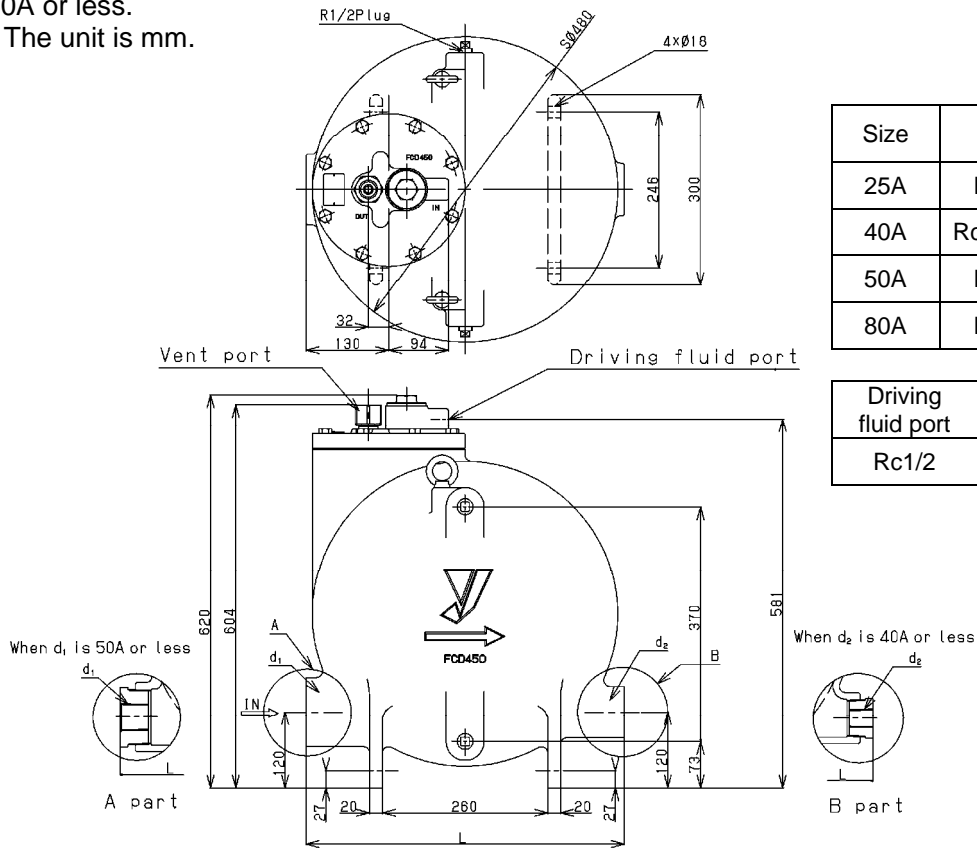
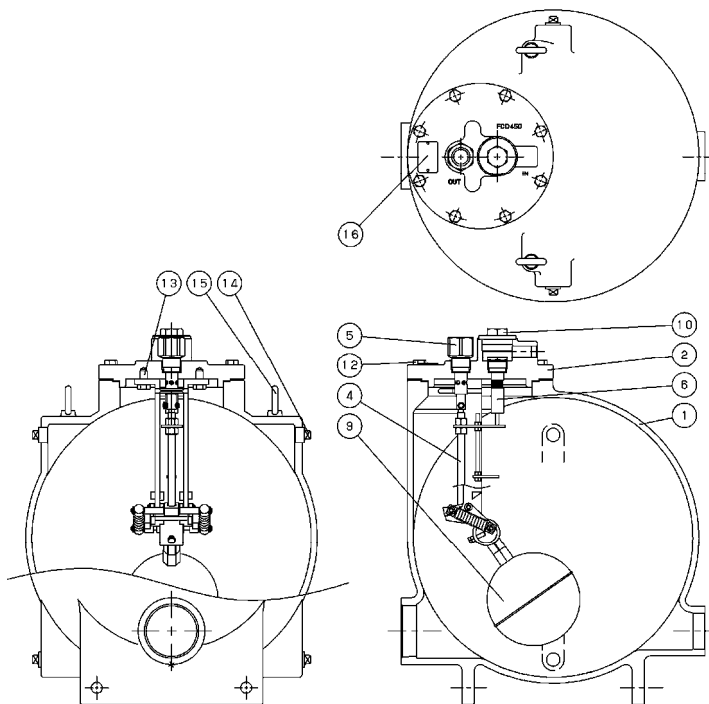

Fig. 1: Dimensions

3. Structure



No.	Part name
1	Body
2	Cover
4	Vent valve P
5	Vent valve seat
6	Inlet valve P
9	Float
10	Cap
12	Hex bolt
13	Hex bolt
14	Square head plug
15	Eye bolt
16	Name Plate

Fig. 2: Structure

4. Operation

<State 1>

Condensate flows into body [1] via the condensate inlet and then float [9] moves upward due to buoyancy. (See Fig. 3.) In this state, vent valve part of vent valve P is open and inlet valve part of inlet valve P is closed.

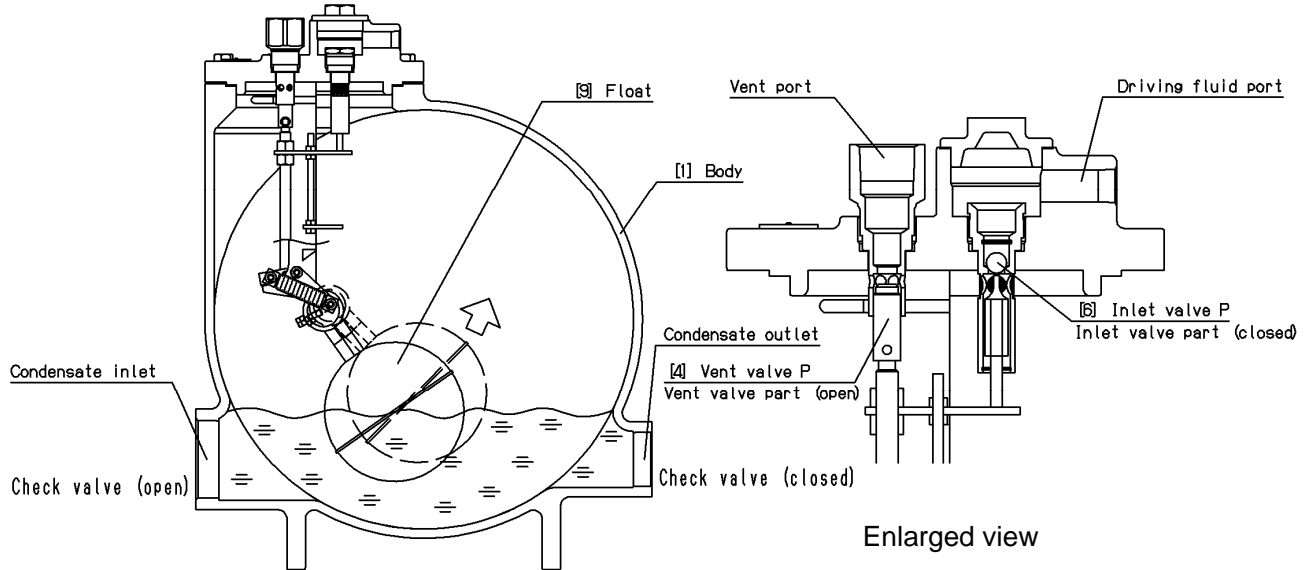

Fig. 3

<State 2>

When condensate level rises and float [9] reaches the height at which vent valve part of vent valve P [4] closes, inlet valve part of inlet valve P [6] opens, and driving pressure enters body [1]. Condensate inside body [1] is transferred to condensate outlet and discharged. (See Fig. 4.) When condensate is discharged, float [9] moves downward in line with water level in body [1]. When it drops to the height at which vent valve part of vent valve P [4] opens, inlet valve part of inlet valve P [6] is closed. Then, internal pressure is released by vent valve, returning to the above state 1.

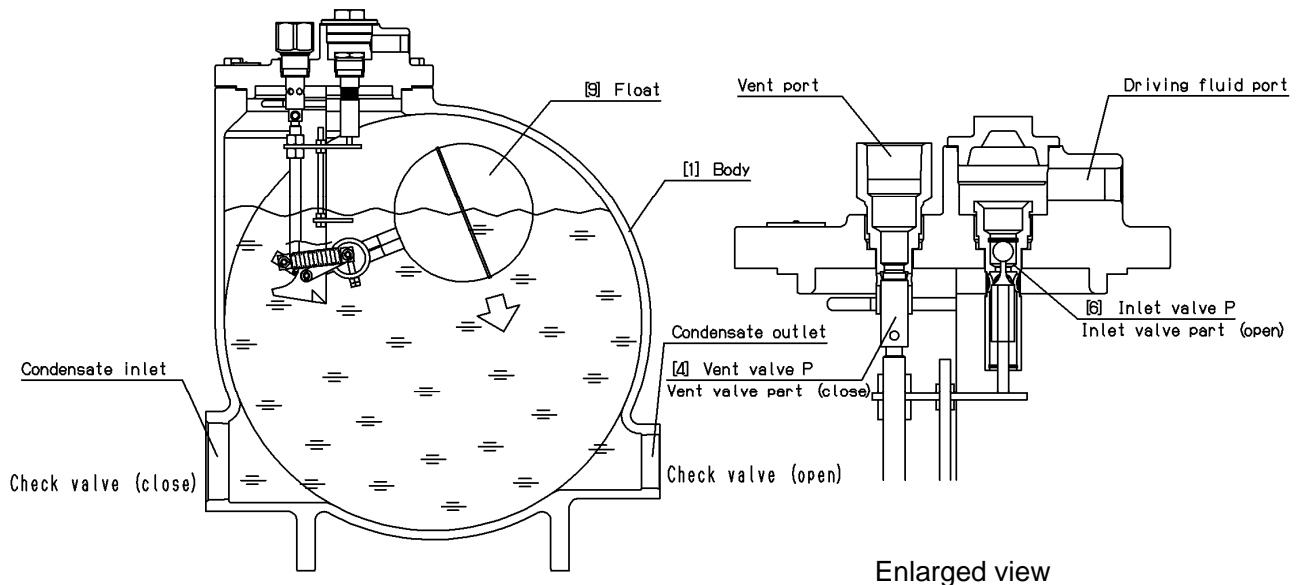
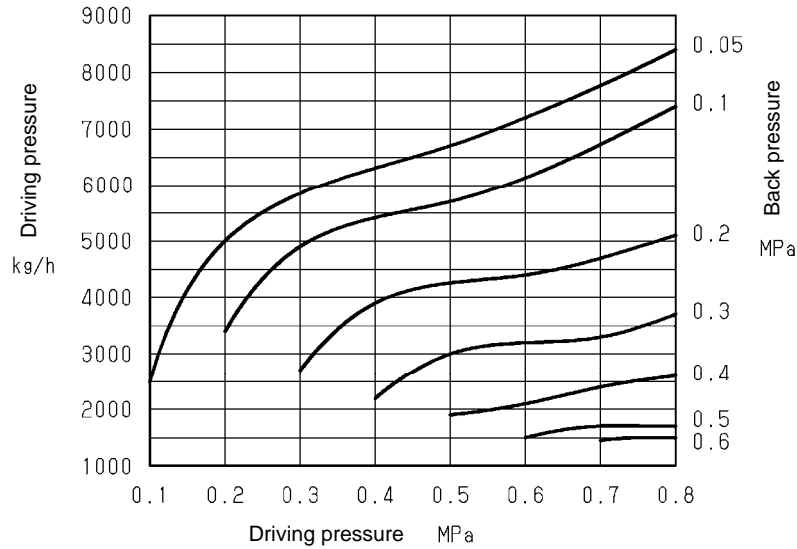

Fig. 4

5. Flow rate

<Driving fluid: steam>



<Driving fluid: air>

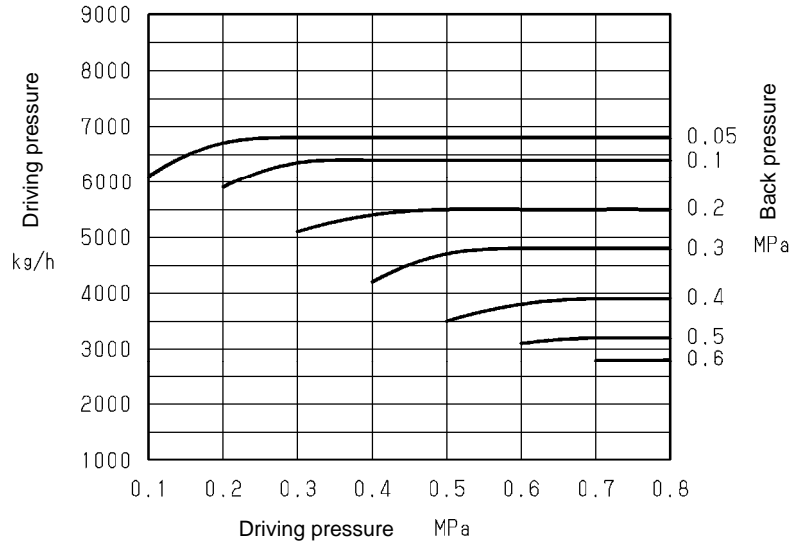

* Flow rate described above indicates condensate volume when condensate flow-in height is 1,000 mm above the bottom of the product. (See 6.1 Piping example)

Discharge capacity varies depending on condensate flow-in height. Multiply the volume by the following factors according to condensate flow-in height.

* The height below is the level above the bottom of the product

Driving fluid	Condensate flow-in height [mm]			
	800	1000	1200	1400
Steam	0.85	1.00	1.05	1.15
Air	0.85	1.00	1.15	1.30

Discharge capacity varies depending on size of condensate inlet and outlet. Multiply the volume by the following factors according to size.

Driving fluid	Size (Condensate inlet – outlet)			
	80A-50A	50A-50A	40A-40A	25A-25A
Steam	1.00	0.90	0.70	0.35
Air	1.00	0.95	0.70	0.30

6. Installation

6.1 Piping example

<Open system>

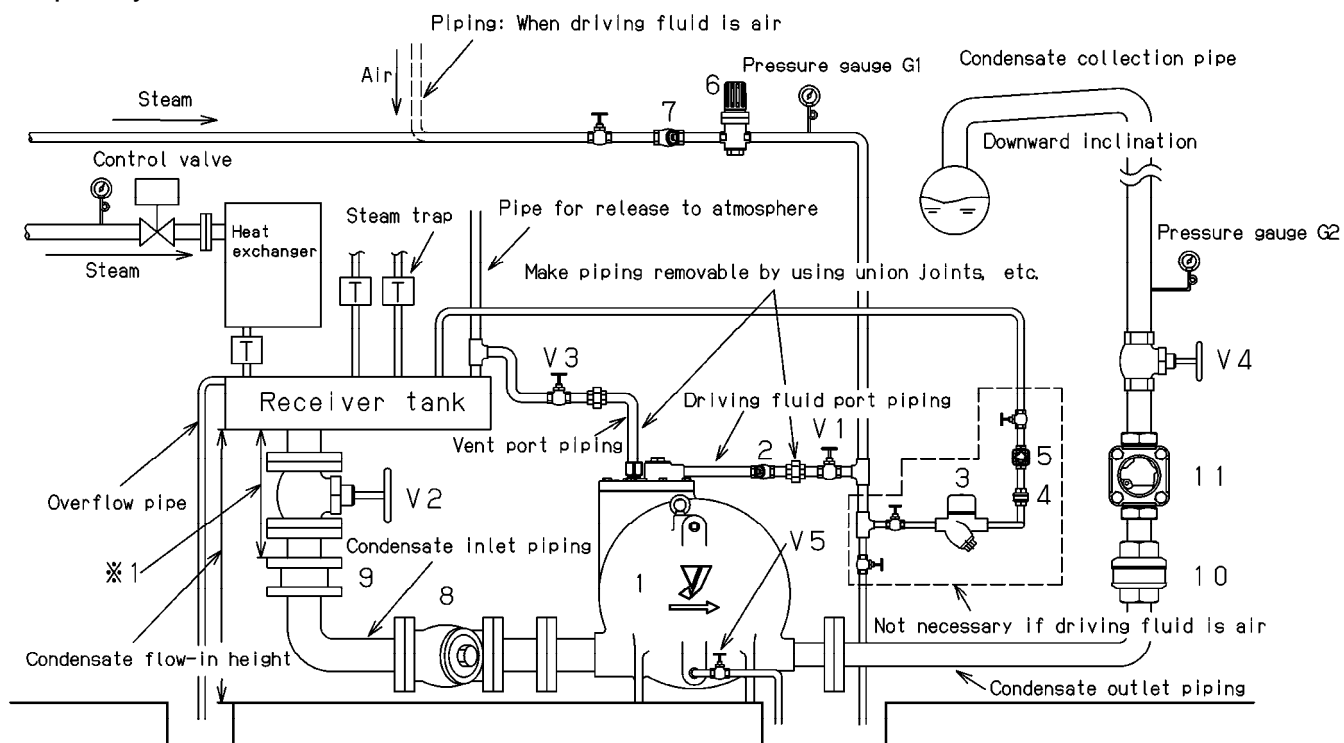

Fig. 5

※1 : Install SCV-3 at least 750mm from the bottom of the receiver tank.

No.	Name	No.	Name	No.	Name
1	Pumping Trap PF-7000	6	Pressure reducing valve GD-30 15A (GD-1000T 15A if driving fluid is air)	11	Sight glass SLM-1S or 1F 50A
2	Strainer SY-5 15A (80 mesh)	7	Strainer SY-5 15A (80 mesh)		
3	Steam trap TD-10NA 15A	8	Strainer SY-40 80A (40 mesh)		
4	Check valve SCV-2 or 3 15A	9	Check valve SCV-3 80A		
5	Sight glass SLM-1S 15A	10	Check valve SCV-2 or 3 50A		

<Closed system>

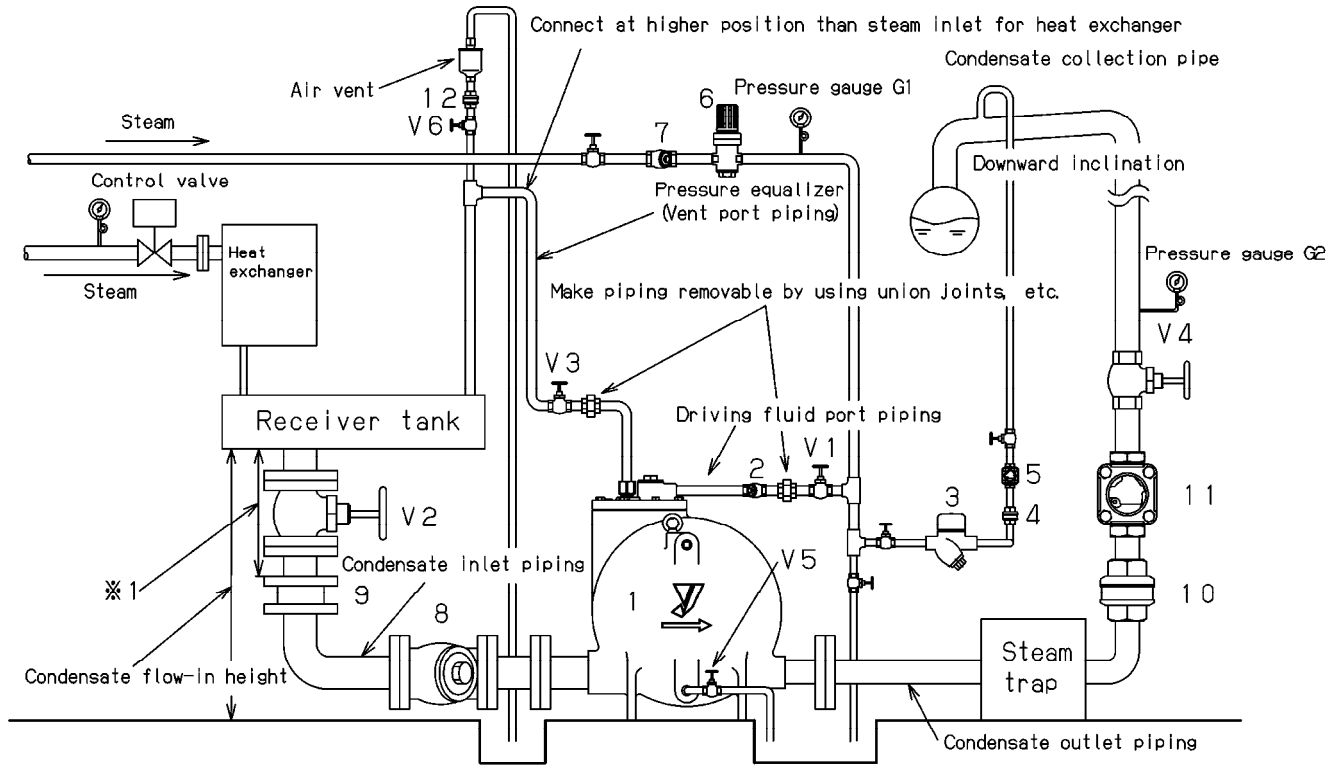

Fig. 6

※1 : Install SCV-3 at least 750mm from the bottom of the receiver tank.

No.	Name	No.	Name	No.	Name
1	Pumping Trap PF-7000	6	Pressure reducing valve GD-30 15A	11	Sight glass SLM-1S or 1F 50A
2	Strainer SY-5 15A (80 mesh)	7	Strainer SY-5 15A (80 mesh)	12	Check valve SCV-2 or 3 15A
3	Steam trap TD-10NA 15A	8	Strainer SY-40 80A (40 mesh)		
4	Check valve SCV-2 or 3 15A	9	Check valve SCV-3 80A		
5	Sight glass SLM-1S 15A	10	Check valve SCV-2 or 3 50A		

6.2 Warning and caution for installation



Warning

1. Condensate may blow out from vent port following driving pressure drop or stop or failure of the product. Connect a pipe to the port and extend the pipe to safe place.
* Failure to follow this notice may scald your skin by blowout of condensate.



Caution

1. Before installing the product, remove foreign substances and scale from the piping, and note that seal materials must not flow into the inside of the product or piping.
* Commingling of foreign substances such as scale or seal material leads to malfunction of the product.
2. Before connecting pipes, check the condensate inlet, condensate outlet, driving fluid port and vent port. (See 6.1. Piping example.)
* The product does not function properly if piping is not connected correctly.
3. Install the product horizontally, with vent port facing upward.
* The product does not function properly if installation direction is not correct.
4. Connect the product to piping firmly.
* Failure to follow this notice may cause burn injury by leakage of condensate from joints due to vibration.
5. Use union joints, etc. for connection with pipes. (See 6.1. Piping example.)
* If union joints, etc. are not used, removal of pipes may become impossible or require more time in disassembly/assembly for maintenance/inspection.
6. Do not apply any shocks such as water hammer. Avoid using quick open/close valves at inlet /outlet side of the product.
* Failure to follow this notice may cause burn injury by blowout of condensate caused by excessive shock on the product.
7. Do not disassemble the product unless necessary.
* Failure to follow this notice may hamper proper operation of the product.
8. Attach strainers in front of condensate inlet and driving fluid port. (See 6.1. Piping example.)
* If strainers are not attached, the product does not function properly due to intrusion of dust, etc. into the product.
9. Check valve is not connected to the product. Be sure to install check valve at inlet and outlet of the product. (See 6.1. Piping example.)
* Without check valve, the product do not function as pumping trap.
10. If driving fluid is steam, install a steam trap to the pipe on driving fluid port for condensate discharge. (See 6.1. Piping example.)

11. Be sure to secure maintenance space needed for disassembly and repair of the product. (See Fig 7) The unit is mm.

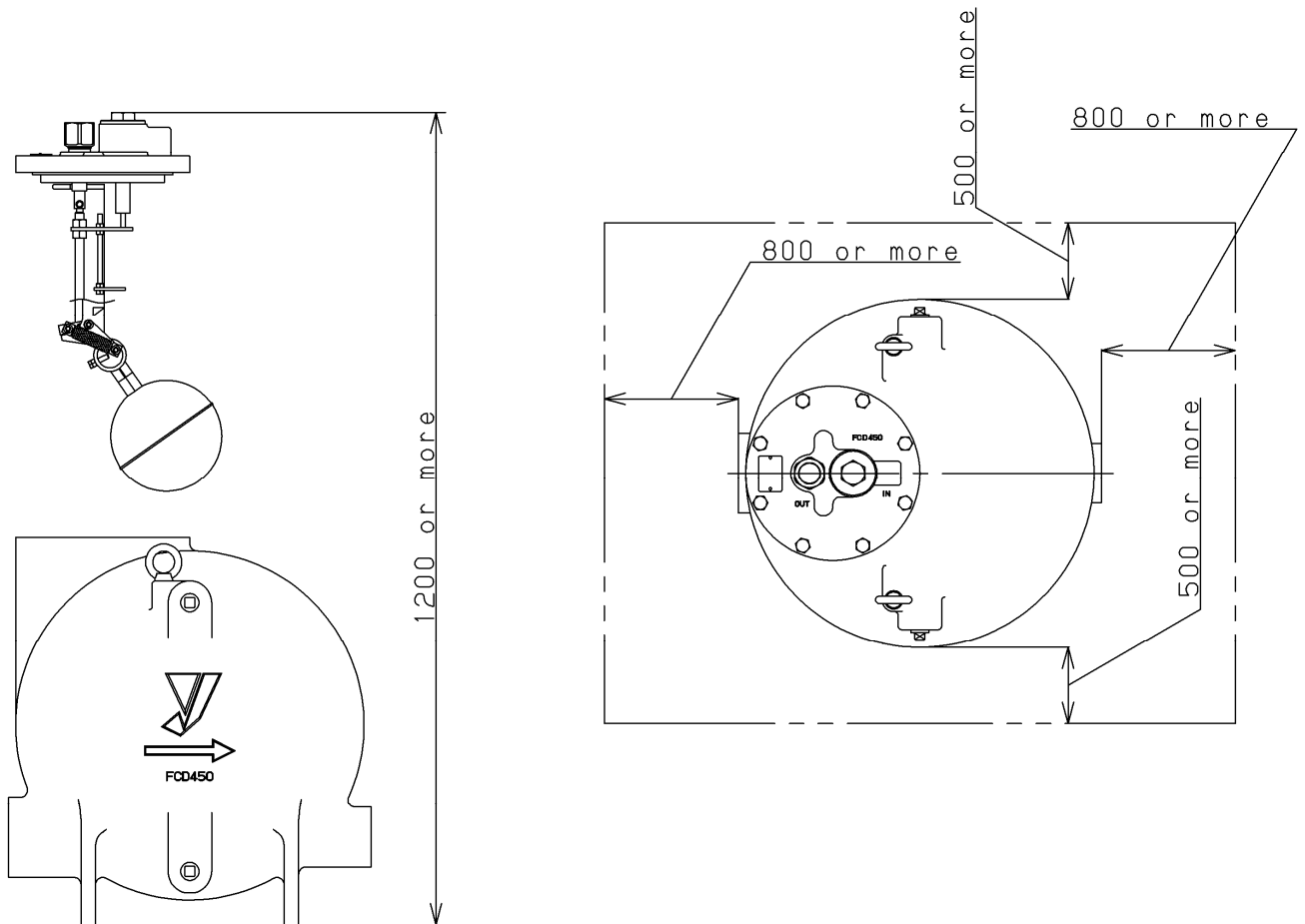

Fig. 7: Maintenance space

12. Recommended height of the condensate inlet is 1000 mm or more. (See 6.1. Piping example.)
13. Cautions for open system
Be sure to attach an overflow pipe to the receiver tank and lead the pipe to a safe place. (See Fig. 5)
14. Cautions for closed system
- Be sure to use steam as driving fluid. Contact us if you have to use fluid other than steam.
 - Be sure to install pressure equalizer at a place higher than the steam inlet of the heat exchanger. (See Fig. 6.)
 - Be sure to attach air vent valve and check valve to pressure equalizer. (See Fig. 6.)

7. Operation procedure

7.1 Warning and caution for operation

Warning

1. Do not touch the product by bare hands when steam is flowing.
* Failure to follow this notice may cause burn or injury.
2. Confirm that pipe joints are connected firmly and not unstable before letting the steam flow.
* Failure to follow this notice may cause blowout of steam or condensate, resulting in scalds.

Caution

1. Open stop valves on pipes slowly to prevent water hammer.
* Sudden opening of stop valves may cause hunting or water hammer, damaging the devices.
2. The product is activated by driving pressure. If driving pressure is lower than back pressure on the outlet side, condensate continues to flow into the product and the product is filled with condensate. In this state, driving pressure port is blocked by condensate and condensate cannot be pushed out by driving pressure. Therefore, if driving fluid is steam, be sure to confirm that sufficient pressure exists in driving steam line using pressure gauge G1 before start of operation. (See 6.1. Piping example.)
* Actions to be taken when the product is filled with condensate fully
Close valve V1 on driving steam line and valve V2 at condensate inlet first, and then open blow valve V5 at the bottom of the product for drainage. (See 6.1. Piping example.)
3. The most appropriate value of driving pressure is back pressure at outlet side + 0.1 to 0.2 MPa.
* Enlarged differential pressure leads to cause water hammer.

7.2 Operation method

<Open system>

See Fig. 5 for marks and numbers of stop valves. Stop operation immediately when water hammer occurs, and close operating stop valves.

- 1: Open stop valve V4 at condensate outlet slowly until it is full open.
- 2: Open stop valve V3 at vent port slowly until it is full open.
- 3: Open stop valve V1 at driving fluid port slowly until it is full open.
- 4: Confirm by pressure gauge G1 that driving pressure is sufficient, and then open stop valve V2 at condensate inlet slowly until it is full open.
- 5: If the product is activated and transfer of condensate is confirmed through sight glass 11, startup of operation is completed.

<Closed system>

See Fig. 6 for marks and numbers of stop valves. Stop operation immediately when water hammer occurs, and close operating stop valves.

- 1: Open stop valve V4 at condensate outlet slowly until it is full open.
- 2: Open stop valve V3 on pressure equalizer (pipe at vent port) slowly until it is full open.
- 3: Open stop valve V1 at driving fluid port slowly until it is full open.
- 4: Open stop valve V6 slowly until it is full open for air ventilation from pipe at condensate inlet by air vent.
- 5: Confirm by pressure gauge G1 that driving pressure is sufficient, and then open stop valve V2 at condensate inlet slowly until it is full open.
- 6: If the product is activated and transfer of condensate is confirmed through sight glass 11, startup of operation is completed.

8. Maintenance

Most of product failure is due to foreign substance inside piping. Be careful for foreign substance inside piping fully. Note that the customer will be required to pay repair charge for any defect that occurs due to foreign matter. Please understand.

8.1 Warning and caution for maintenance and inspection

Warning

1. When performing periodic inspection or part replacement, be sure to confirm that pressure inside the product and pipes is equivalent to atmospheric pressure. Cool down the body of the product until it can be touched by bare hands. Inspection/replacement should be done by skilled experts (staff of facility management/engineering companies, etc.).
 - * Failure to follow this notice may result in injury by residual pressure in the product or pipes. If the temperature is high, it may result in scalds.
2. If leakage from the joint between the body and cover is observed, replace the gasket with a new one, without re-tightening hex bolts.
 - * Re-tightening of hex bolt may damage the gasket, causing steam blowout and scalds.

Caution

1. Perform periodic inspection to maintain functions and performance of the product.
 - * General users should ask experts (staff of facility management/engineering companies, etc.) to perform periodic inspection.
2. After leaving the product not operated for a long period, perform periodic inspection before start-up of operation. After periodic inspection, start operation again according to “7. Operation procedure.”
 - * Failure to follow this notice may cause malfunction due to rust generated inside the product or pipes.

8.2 Daily and Periodic inspection/Periodic replacement

Perform daily and periodic inspection, periodic replacement to maintain functions and performance of the product.

8.2.1 Daily inspection

Inspect the following items once a day. (See 6.1. Piping example.)

Items	How to inspect	Remedy
Driving pressure	Confirm that it is predetermined pressure using pressure gauge G1.	Control driving pressure by adjusting pressure reducing valve 6.
Condensate discharge condition	Perform visual check by sight glass 11.	If condensate is not discharged, see “8.3 Troubleshooting”.
Outside leakage	Confirm by visual check.	See “8.3 Troubleshooting”.

8.2.2 Periodic inspection

Check the following items once a year, in addition to daily inspection items. (See Fig. 8 for the numbers inside the brackets [].)

Items	How to inspect	Remedy	Actions to be taken
Float [9] switching operation	<ol style="list-style-type: none"> 1. Close all stop valves in pipes that are connected to the product. 2. Remove square head plug [14] from the cover and forcibly let water flow in from there. 3. Confirm the “click” noise generated when vent valve P [4] is switched. 4. Open blow valve V5 at the bottom of the product and discharge water. 5. Confirm the “click” noise generated when vent valve P [4] is switched. 	If not switched, replace vent valve P [4] and float [9].	See 8.4.4.
Clogging of strainer	Disassemble and confirm by visual check.	* If the strainer is clogged, clean or replace it.	

8.2.3 Periodic replacement

The following parts should be replaced at recommended intervals to maintain functions and performance of the product. Replace the parts at the recommended intervals. (See Fig. 8 for the numbers inside the brackets [].)

Caution

1. Replace the parts periodically at the recommended intervals.

* Failure to perform periodic part replacement may cause malfunction of the product.

● List of parts to be replaced periodically

Part name	Recommended replacement intervals
Vent valve P [4]	2 years or 120,000 cycles of operation, whichever is earlier
Vent valve seat [5]	2 years or 120,000 cycles of operation, whichever is earlier
Inlet valve P [6]	2 years or 120,000 cycles of operation, whichever is earlier
Float [9]	2 years or 120,000 cycles of operation, whichever is earlier

2. Be careful to prevent dropping of parts in disassembly. Put disassembled parts on a soft cloth to prevent scratching.

* If parts are scratched, malfunction may occur, resulting in functional deterioration.

3. Be sure to replace with specified parts. Never remodel the product.

* Failure to follow this notice may cause scalds or injury due to breakage of the product, blowout of steam or condensate, or abnormal behavior.

4. Do not use old parts again after replacement.

* If such old parts are used by mistake, malfunction may occur.

8.3 Troubleshooting (See 6.1 Piping example for marks and numbers of stop valves, and see Fig. 8 for the numbers inside the brackets [].)

Trouble	Cause	Remedy
Condensate is not discharged.	Stop valve V2 at condensate inlet is closed.	Open stop valve V2.
	Pipes at condensate inlet and condensate outlet are connected the other way around.	Connect the pipes correctly. (See 6.1. Piping example)
	Pipes at driving pressure inlet and discharge port are connected the other way around.	Connect the pipes correctly. (See 6.1. Piping example.)
	Strainer 8 at condensate inlet is clogged.	Disassemble strainer 8 and clean the screen.
	Stop valve V4 at condensate outlet is closed.	Open stop valve V4.
	Stop valve V3 on vent port piping (pressure equalization pipe) is closed.	Open stop valve V3.
	Driving pressure is too low against back pressure.	Control the pressure to a specified level by adjusting reducing valve 6.
	Stop valve V1 on pipe at driving fluid port is closed.	Open stop valve V1.
	Strainer 2 on pipe at driving fluid port is clogged.	Disassemble strainer 2 and clean the screen.
	Driving pressure exceeds the specified range.	Adjust driving pressure according to specifications. (See 1. Specifications.)
	Check valve 9 at condensate outlet is installed in opposite direction. Or the valve does not open.	If in opposite direction, install in proper direction. Replace if it does not open.
	Check valve 10 at condensate outlet is installed in opposite direction. Or the valve does not open.	If in opposite direction, install in proper direction. Replace if it does not open.
	Air vent is broken.	Replace air vent.
	Stop valve V6 on pressure equalization pipe is closed.	Open stop valve V6.
	Leakage from vent valve part at vent valve P [4].	Disassemble the product, and perform cleaning if the trouble is caused by scales in vent valve part of vent valve P [4]. If the trouble is caused by parts failure such as scratches on the part, replace vent valve P [4] and vent valve seat [5]. (See Fig 8.4.4.)
Leakage of steam from inlet valve P [6].	Disassemble the products and replace inlet valve [6]. (See Fig 8.4.4.)	
Float [9] is broken.	Disassemble the products and replace float [9]. (See Fig 8.4.4.)	

Trouble	Cause	Remedy
Leakage of steam to external area of the product.	Leakage from gasket [3] between body [1] and cover [2].	Replace gasket [3]. (See Fig. 8.4.4.)
	Leakage from gasket [7] between vent valve seat [5] and cover [2].	Replace gasket [7]. (See Fig. 8.4.4.)
	Leakage from gasket [11] between cap [10] and cover [2].	Replace gasket [11]. (See Fig. 8.4.4.)
	Leakage from square head plug [14].	Remove square head plug [14], replace seal tape with a new one and fit the plug again.

8.4 Disassembly/assembly methods

8.4.1 Warning and caution for disassembly/assembly (See Fig. 8 for the numbers inside the brackets []).

 Warning
<p>1. Be sure to release internal pressure of the product, pipes and devices completely and cool down the product before disassembly and inspection. Do not touch the product by bare hands until it is cooled down completely.</p> <p>* Failure to follow this notice may cause injury or burn by residual pressure.</p>

 Caution
<p>1. Use a container to receive condensate that flows out when performing disassembly.</p> <p>* Failure to follow this notice may stain peripheral devices by condensate.</p> <p>2. Confirm that seats including inlet valve P [6], vent valve P [4] and vent valve seat [5] are free from scratches, dents and stains. Clean if stained. Replace scratched, dented parts.</p> <p>* They may cause malfunction.</p> <p>3. In assembly, fit parts firmly and tighten bolts evenly and diagonally to prevent uneven torque.</p> <p>* Loose fitting and uneven tightening may cause malfunction or external leakage.</p> <p>4. Be sure to use specified parts to repair the product. Never remodel the product.</p> <p>* Failure to follow this notice may cause scalds or injury due to breakage of the product, blowout of steam or condensate, or abnormal behavior.</p> <p>5. Replace gaskets with new ones at the time of assembly.</p> <p>* They are consumables. Using old one, replaced gaskets again may cause external leakage.</p>

8.4.2 Disassembly method (See Fig. 8)

Tools used

Name of tool	Details (size, nominal size, etc.)
Spanner	Width across flats: 24 mm, 41 mm
Hex socket wrench	Width across flats: 19 mm, 32 mm
Socket wrench	Use with hex socket wrench.

Procedure 1: Loosen cap [10] using socket wrench (width across flats: 32 mm), and then remove cap [10] and gasket [11].

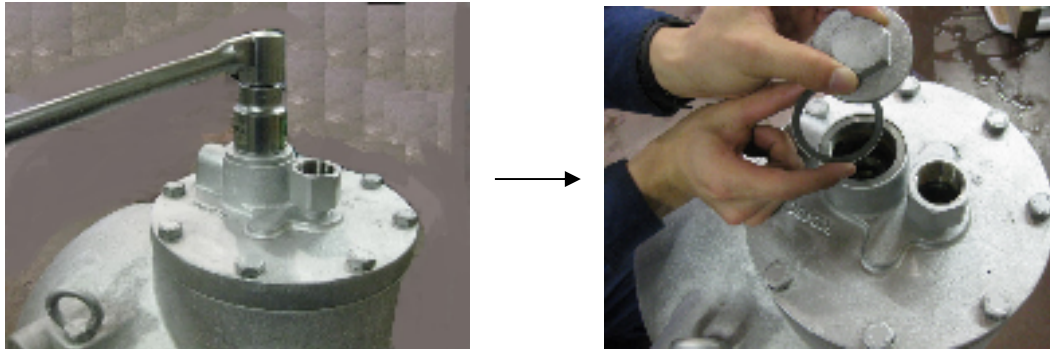

Procedure 2: Loosen inlet valve seat [6] using socket wrench (width across flats: 32 mm), and then remove inlet valve seat [6] and gasket [8].

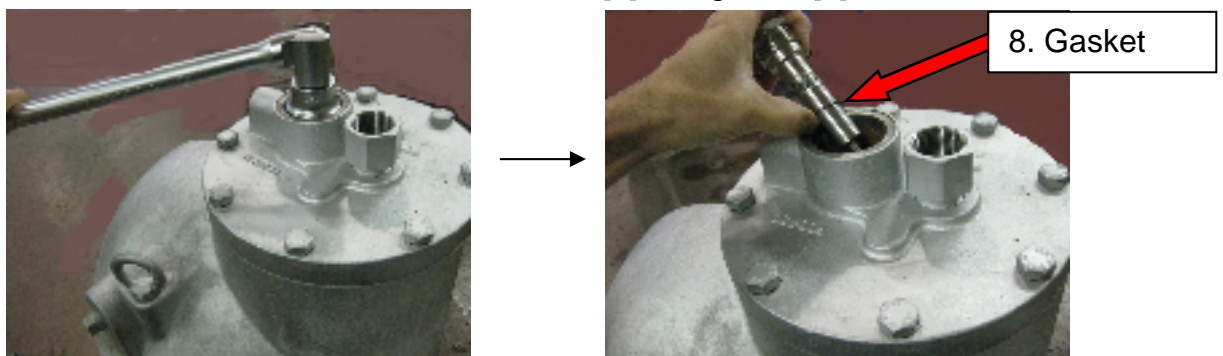

Procedure 3: Loosen inlet valve seat [5] using spanner (width across flats: 41 mm), and confirm that it can be turned by hand.

*When it is removed, vent valve seat part of vent valve P [4] can be damaged. Be sure not to remove it.

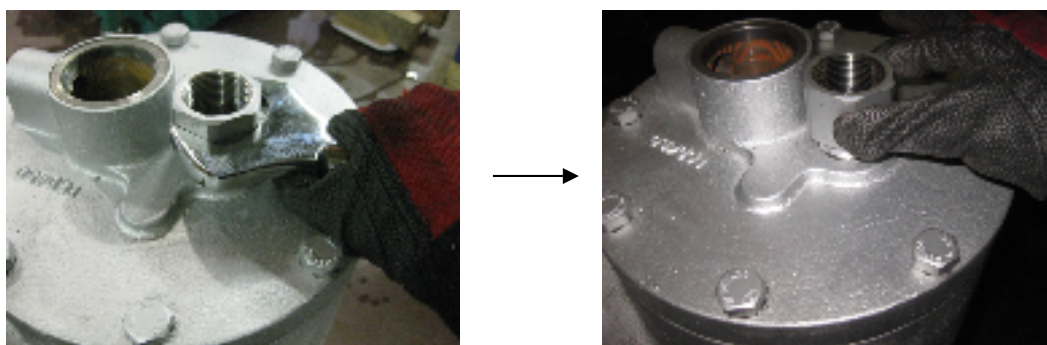

Procedure 4: Remove hex bolts [12] using socket wrench (width across flats: 19 mm), and remove cover [2] and gasket [3] from body [1].

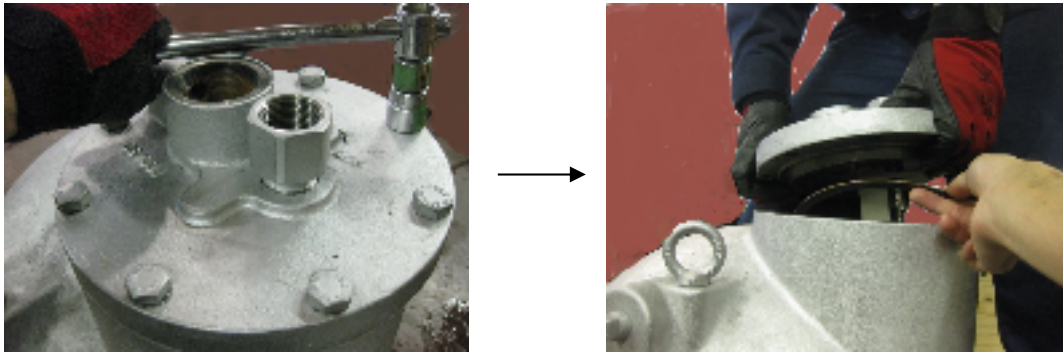

Procedure 5: Fix float arm part of vent valve P [4] using spanner (width across flats: 24 mm), apply spanner (width across flats: 24 mm) to hex part of float [9], and remove float [9].

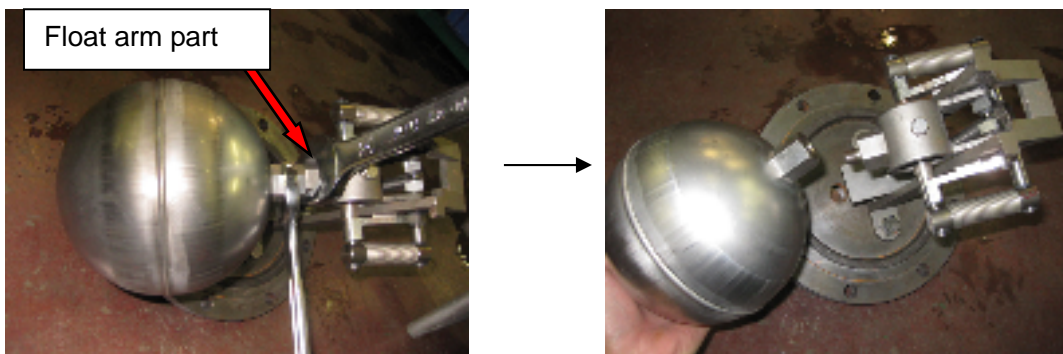

Procedure 6: Remove 2 hex bolts [13] attached to cover [2] using socket wrench (width across flats: 19 mm), and remove vent valve P [4].

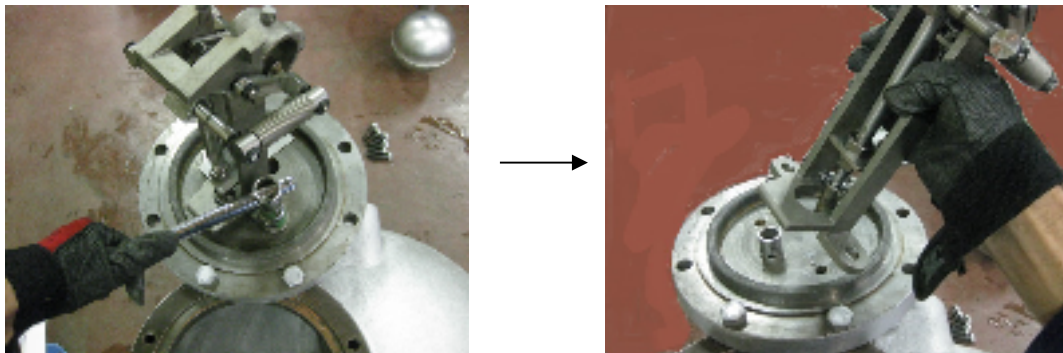

Procedure 7: Remove vent valve seat [5] and gasket [7] together.

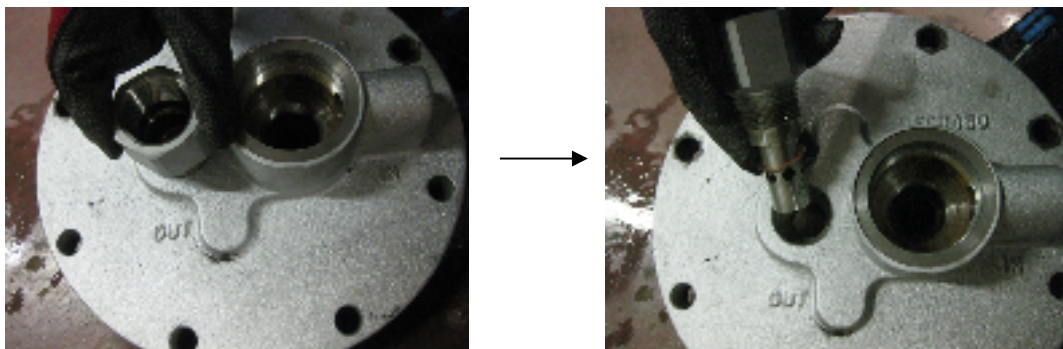

8.4.3 Assembly method (See Fig. 8)

*Tools used

Name of tool	Details (size, nominal size, etc.)
Torque wrench	Any of those that can apply 50, 70, 100, 140 N•m torque (Use hex socket)
Spanner torque wrench	Width across flats of wrench: 24 mm, any of those that can apply 50 N•m torque
	Width across flats of wrench: 41 mm, any of those that can apply 140 N•m torque
Spanner	Width across flats: 24 mm
Hex socket wrench	Width across flats: 19 mm, 32 mm

Procedure 1: Apply lubricant oil (machine oil) to new gasket [7], let it into vent valve seat [5], and put it into cover [2] by hand.

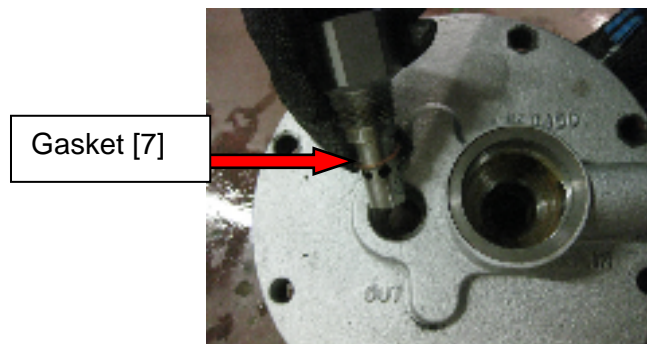

Procedure 2: Switch vent valve P [4] as below.

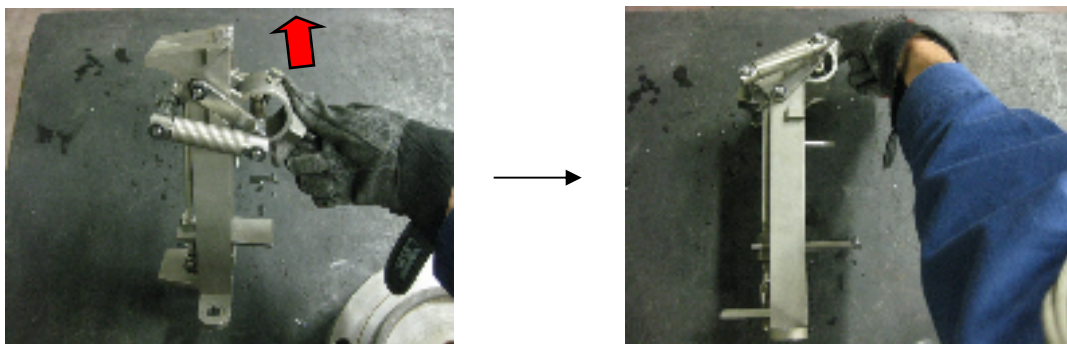

Procedure 3: Put vent valve of vent valve P [4] into vent valve seat [5]. Then, place vent valve P [4] at the position of pin (2 parts) of cover [2].

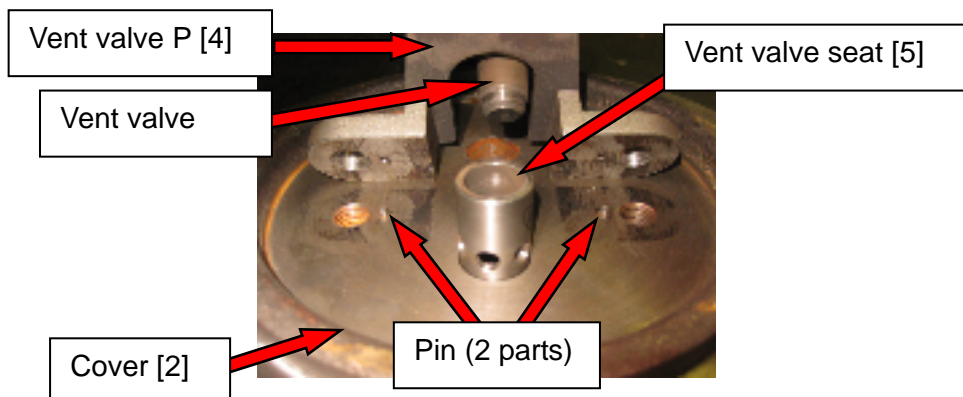

Procedure 4: Apply Loctite 620 to screw part of hex bolt [13], and attach vent valve P [4] to cover [2] at 50 N•m torque using wrench (width across flats: 19 mm).

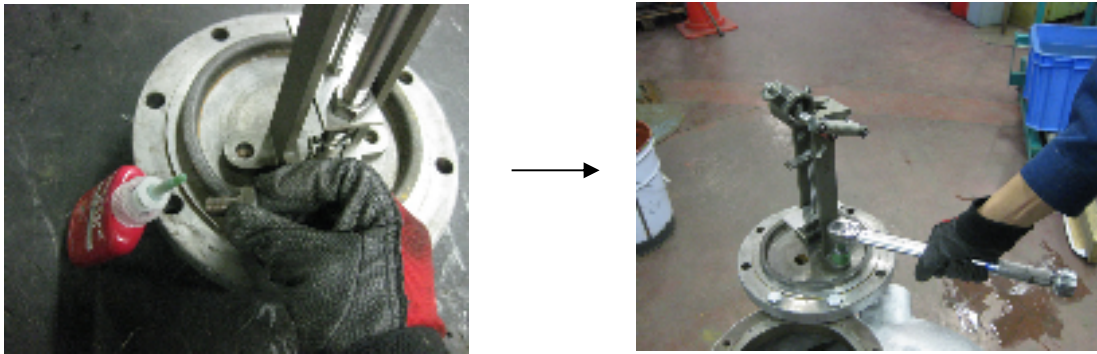

Procedure 5: Assemble float [9] to vent valve P [4]. Firstly, apply Loctite 620 to screw part of vent valve P [4]. Then, fix float arm part using spanner (width across flats: 24 mm), tighten the hexagonal portion of float [9] at 50 N•m torque using spanner wrench (width across flats: 24 mm).

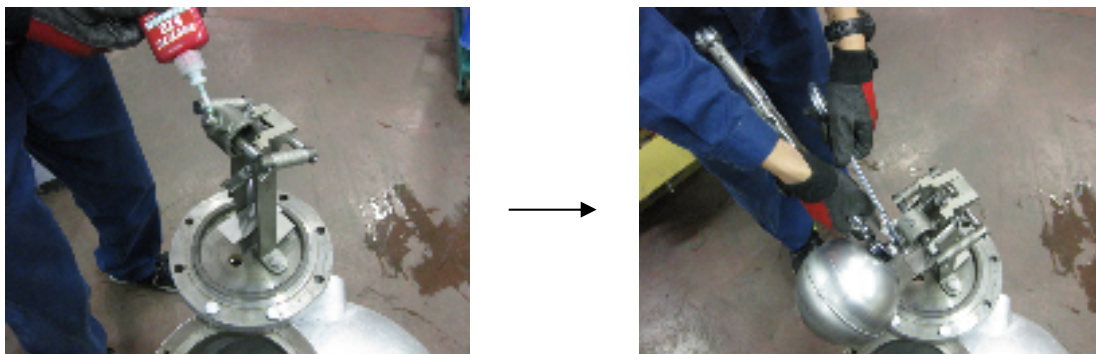

Procedure 6: Apply paste agent to whole part of new gasket [3] and install it on the ditch part of body [1]. (Recommended paste: SOLVEST110 manufactured by STT Inc.)

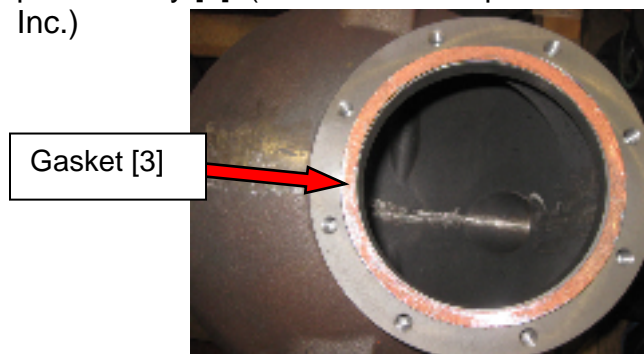

Procedure 7: Attach cover [2] to body [1]. Tighten hex bolt [12] at 70 N•m torque using torque wrench (width across flats: 19 mm).



Procedure 8: Apply Loctite 620 to screw part of inlet valve P [6]. Then apply lubricant oil (machine oil) to new gasket [8], let it into inlet valve P [6], and put it into cover [2] by hand.

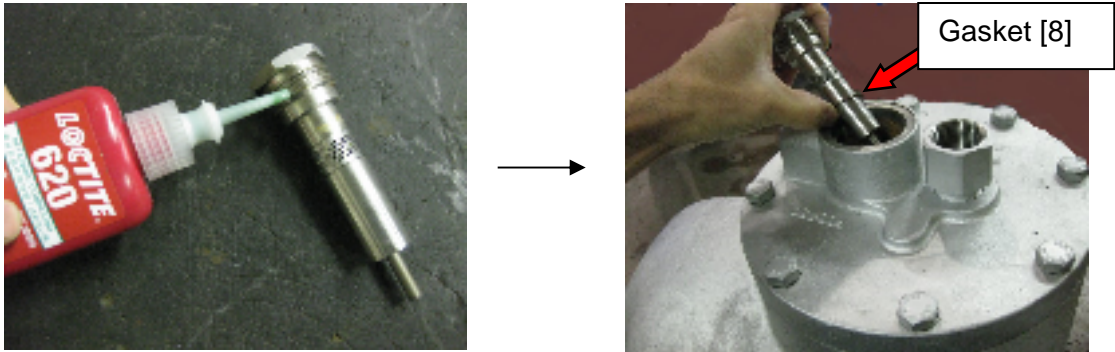

Procedure 9: Attach inlet valve P [6] at 140 N•m torque using torque wrench (width across flats: 32 mm). Attach vent valve seat [5] at 140 N•m torque using spanner torque wrench (width across flats: 41 mm).

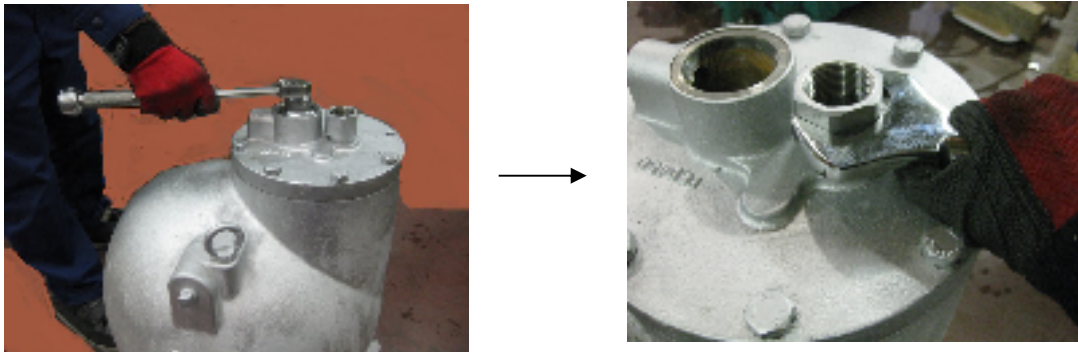

Procedure 10: Apply paste agent to whole part of new gasket [11] and put it on cover [2]. (Recommended paste: SOLVEST110 manufactured by STT Inc.) Attach cap at 100 N•m torque using torque wrench (width across flats: 32 mm).



8.4.4 How to replace each part

- How to replace gasket [3]
Disassemble the product according to procedure 4 in “8.4.2 Disassembly method”, and replace and assemble the gasket according to procedure 6 and 7 in “8.4.3 Assembly method”.

- How to replace gasket [11]
Disassemble the product according to procedure 4 in “8.4.2 Disassembly method”, and replace and assemble the gasket according to procedure 6 and 7 in “8.4.3 Assembly method”.

- How to replace gasket [7]
Disassemble the product according to procedures 3, 4, 6 and 7 in “8.4.2 Disassembly method”, and replace and assemble the gasket according to procedures 1 to 6, 7 and 9 in “8.4.3 Assembly method”.

- How to replace float [9]
Disassemble the product according to procedures 4 and 5 in “8.4.2 Disassembly method”, and replace and assemble the gasket according to procedures 5 to 7 and 9 in “8.4.3 Assembly method”.

- How to replace inlet valve P [6]
Disassemble the product according to procedures 1 and 2 in “8.4.2 Disassembly method”, and replace and assemble the inlet valve P according to procedures 8 to 10 in “8.4.3 Assembly method”.

- How to replace vent valve P [4] and vent valve seat [5]
Disassemble the product according to procedures 3 to 7 in “8.4.2 Disassembly method”, and replace and assemble the gasket according to procedures 1 to 7 and 9 in “8.4.3 Assembly method”.

- How to replace cover set
Disassemble the product according to procedures 4 in “8.4.2 Disassembly method”, and replace and assemble the cover set according to procedures 5 to 7 in “8.4.3 Assembly method”.

9. Exploded view

*(Enclosed parts are offered as consumables.)

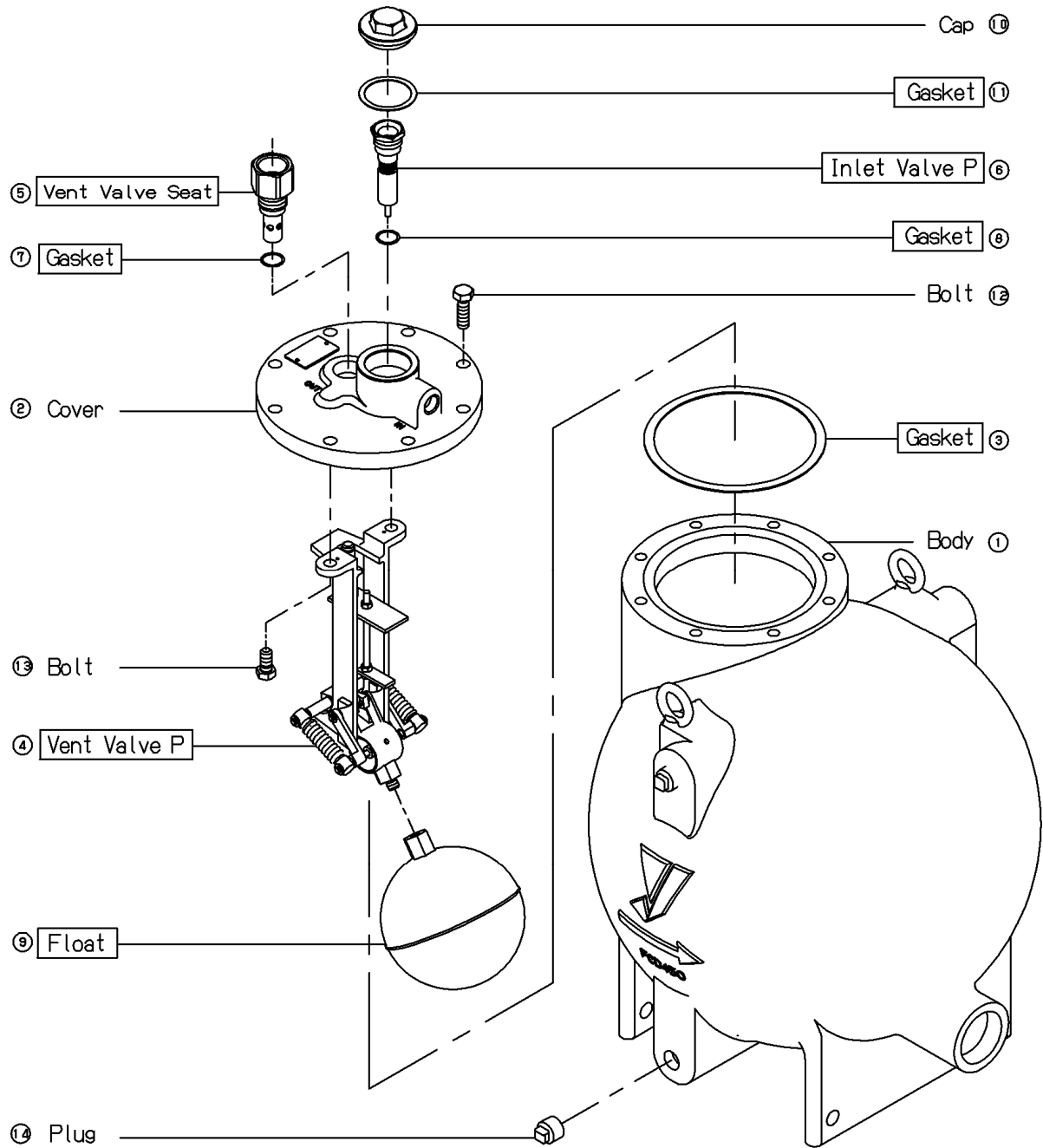

Fig. 8. Exploded view

Warranty Information

1. Limited warranty

This product has been manufactured using highly-advanced techniques and subjected to strict quality control. Please be sure to use the product in accordance with instructions on the manual and the label attached to it.

Yoshitake warrants the product to be free from any defects in material and workmanship under normal usage for a period of one year from the date of receipt by the original user, but no longer than 24 months from the date of shipment from Yoshitake's factory.

2. Parts supply after product discontinuation

This product may be subject to discontinuation or change for improvement without any prior notice. After the discontinuation of the product, Yoshitake supplies the repair parts for 5 years otherwise individually agreed.

3. This warranty does not cover the damage due to any of below:

- (1) Valve seat leakage or malfunction caused by foreign substances inside piping.
- (2) Improper handling or misuse.
- (3) Improper supply conditions such as abnormal water pressure/quality.
- (4) Water scale or freezing.
- (5) Trouble with power/air supply.
- (6) Any alteration made by other than Yoshitake.
- (7) Use under severe conditions deviating from the design specifications (e.g. in case of corrosion due to outdoor use).
- (8) Fire, flood, earthquake, thunder and other natural disasters.
- (9) Consumable parts such as O-ring, gasket, diaphragm and etc.

Yoshitake is not liable for any damage or loss caused by malfunction or defect of the product.

YOSHITAKE

INTERNATIONAL DEPT.

955-5, Miyamae, Irukadeshinden, Komaki, Aichi, 485-0084, Japan

Phone: +81-568-75-4432 Fax: +81-568-75-4763

E-mail: Intntl@yoshitake.co.jp